



***THE
ULTIMATE
SURVIVAL
VEHICLE***

TOM BOND
TomsEbooks.com

THE ULTIMATE SURVIVAL VEHICLE

So you woke up one morning and decided that what you saw isn't exactly what you thought the perfect world is supposed to be. You have decided that the "civilized" world as we know it cannot and will not last forever. Perhaps you have decided that the "house of cards" that is our economy and our very way of life will not last much longer at all.

OK, fair enough. You are not the only one that has decided that the time to prepare is before the collapse, not after. There are many aspects of being prepared and although there is no guarantee that any one person could possibly survive any possible event, we do what we can, right?

One of the first things that comes to mind is what will I do and where will I go when the system collapses? Unless you live in a remote area completely isolated from the establishment, you must plan for your transportation from your present location to a more secure and remote location. To do this, you will need a vehicle with far more capabilities than the family station wagon.

So what would be the perfect getaway vehicle? Perhaps a shiny new Hummer - that is what the military is using. They have great off road performance, lots of ground clearance and are fairly reliable. But they do have several drawbacks, they have a unique drivetrain for which getting spares will involve another Hummer, they are very visible, not likely to go unnoticed very long in one of these babies. There is practically no way to modify a Hummer to make it do something that it wasn't designed to do. No extra fuel tanks, no extra tool storage areas, not much interior room or comfort. Besides the price tag of \$105,000 leaves most of us out.

OK, Hummer's are a little pricey and a little narrow in what they can do. How about a sport utility? Maybe a Ford Explorer or a Jeep Cherokee? These vehicles get pretty good gas mileage and seem to hold up pretty good off the road. The main thing to remember when choosing a vehicle is the intended purpose. Most people are not going to be able to put all their stuff in the back of a Jeep, or Explorer, or Isuzu Trooper or whatever. What is required for this mission is a vehicle that can carry a lot of weight, go a very long distance without refueling and go off the road when required without breaking. Also be easily repaired when it needs it. A vehicle that can be easily modified by the averaged Joe (or Jill), and can go unnoticed until needed.

I was a mechanic for many years and have worked on just about every type of motor vehicle and most types of airplanes. I too needed a vehicle that would take my wife and I camping, 4-wheeling, could be used for business and just an all around reliable vehicle. I spent a lot of time deciding what type and exactly which vehicle would be the best compromise and I believe that I have found it.

The vehicle that I chose is a Chevy short wheelbase step-side pickup. It doesn't go off road as well as a Jeep, not as comfy as an Explorer, not as cheap to feed as a Subaru. However, with that said, there is just not much that this truck cannot do. It does great off road, is fairly quiet and comfy, gets decent gas mileage and is easily modified and maintained. One possible drawback is that the truck only has room for three adults and that may not be enough. Perhaps a full-size Blazer, or the king of sport-utes, the Suburban, (which shares the same drive train and most other parts)

would be a suitable choice. The reason many people choose a Chevy over other brands like Ford or Dodge, is not that the truck is inherently superior, rather there is a greater selection of parts and accessories available for Chevy's.

A prime example is the fuel system. I'm sure there are people reading this wondering how a full-sized Chevy truck could go over 1000 miles without refueling? The answer is not some huge, unsafe aftermarket fuel tank sliding around the bed, taking up space that is desperately needed for survival supplies. Not at all. Chevy has produced many variations of its trucks over the years and this has enabled owners to easily modify their trucks without doing lots of engineering and spending tons of money to get a truck that can do whatever is required. My truck came from the factory with fuel tanks mounted on both sides of the frame, they hold 16 gallons each for a total of 32 gallons. The truck gets about 15 MPG when driven conservatively, yielding a range of 480 miles. Not enough. So I started looking around for extra fuel tanks and found that people were charging bunches of money (\$700 and up) for any kind of extra tank that might be useful. So I dug around at the local wrecking yard and noticed that the fuel tank that came under a Chevy Blazer looked like it might fit between the frame rails of my pickup. Guess what? The fuel tank, cross members, skidplates, filler neck and gauge sender were all exactly what was required with no modifications at all. I simply removed the old frame crossmembers, welded in the ones from the Blazer, hung the fuel tank, routed the lines, wired the gage and selector solenoids and I had an extra 40 gallons of fuel, (this was an option, most Blazers came with a 31 gal. fuel tank) for a total cost of about \$80. Not bad.

You should remember that I as not including the cost of labor or development as I did the work myself. The technical details accompany the photographs in the text.

How about an on-board air compressor? It would be nice to be able to run air tools, add air to the tires, run air horns and air lockers in the differentials. There is a company (or perhaps several) that sells both electric and engine driven compressors that can be adapted to just about any vehicle, the cost? About \$700 before installation. I installed one on my truck for about \$100 that can do anything you might actually require away from the shop. The compressor itself and the brackets were taken from a Chevy van in the junkyard. The thermostat housing and upper radiator hose are also specific to the van. A pressure switch from an industrial supply house and a storage tank from the local speed shop are the main pieces. The photos and captions will clear up any questions. The location of the storage tank is not the best for the size of the tank that I chose. I should have chosen a smaller tank as the pinion of the rear differential strikes it during hard off-roading. Fresh air is obtained from the carburetor air cleaner, compressed, plumbed to the pressure switch, aft to the storage tank, and then to the rear fender where there is a standard female quick-disconnect and pressure gauge. The compressor is capable of filling the tank (10 gallon) from 0 to 125 psi in about 3 minutes.

I have run large and small impact wrenches, filled the tires after airing them down for travel in sand and mud. All the components that make up the compressor system were obtained from standard sources and very little difficult fabrication was required. One note however, the compressor was designed to pump Freon around, not compress air. Therefore, when the compressor is running, the engine should not be above idle rpm. Overheating and failure will result if the compressor is engaged while the truck is being driven.

Often, small details mark where a person has had personal experiences

influence modifications. For example, I was sitting at home eating dinner one night long ago when a neighbor came over saying that several kids who lived in the same apartment complex were in the process of removing things from my truck. I ran outside to find that they had already gone, along with my stereo, equalizer, speakers and CB radio. To this day I make a habit of not investing a great deal of money in equipment that can be removed as quickly as these guys did.

So when I bought this truck and began using it to go 4-wheeling with my friends, I realized I needed a CB radio, not the top of the line perhaps but at least something that would suffice. I don't smoke and so there is a huge unused ashtray sitting in the middle of the dash just waiting for something to do. So I bought a small, cheap CB radio and installed it into the well where the ashtray is supposed to go. The neat part is that when the ashtray is closed, the CB is completely hidden from view. It works out fine but there are some drawbacks. When someone said, "you get what you pay for" they weren't kidding. The radio that I bought came with a small price tag and with small performance. The radio is very susceptible to any kind of static or noise and simply does not have the features or performance that one would like to have. The antenna is the top-of-the-line and shielding the power and ground wires have improved the performance but take my word for it, a CB in the ashtray may seem neat but I would not repeat the exercise.

The low-grade CB radio notwithstanding, the electrical system needed help from the moment I bought the truck. The truck did not run for several years before I bought it and so the battery was absolutely dead. A new battery cured that, but I noticed that the voltage on the gauge was fluctuating sometimes into the red zone. Since the voltage regulator in GM alternators is actually located inside the alternator, a new alternator was quickly installed before it ruined the new battery. An example of cheap parts for Chevy's, the alternator cost just \$36. In the future I plan on installing an electric winch at which time the alternator will have to be replaced with a much larger one, along with another battery. At some point I would like to install an on-board ARC welder which comes with a 160 amp alternator. There are countless upgrades that a person could do to the electrical or other systems but you really have to ask, do I really need this? We all have a finite amount of financial resources to work with and if you waste money in one area, you will be short in another.

The drive train in my truck is just the way that the factory made it. It came equipped with a four-speed transmission with a compound (7:1) low gear. The transfer case is a New Process 205. It is very heavy duty and is not likely to break under normal circumstances. Once again, Chevrolet has built components that will bolt right in that are for all intentions unbreakable. You really have to do some soul-searching and money-searching to decide whether or not to upgrade the driveline components with one-ton units. I try to keep the big picture in mind. The money that could be spent on stronger and heavier differentials, wheels and tires could also be used for supplies, raw land or simply saved in gold. If you already have the basics, then perhaps the extra \$3,000 that the heavier drive train would cost may be worth it. Of course, this may be a moot point to the person who has the ability to write a check for a \$35,000 Explorer or even \$105,000 for a new Hummer. As it stands now, I have roughly \$3,500 invested in my truck and I couldn't imagine investing more than \$7-10,000 no matter how much money I had. There are simply better things to spend one's money on. I suppose that this is the idea that I try to keep in mind when I go about my everyday life, try to keep

some sense of priorities with the things that surround you. I know that the search for more money and more expensive possessions has had us constantly striving to do better than our neighbors. This is exactly what got us in this situation to begin with. So I do my best to keep my feet on the ground and not want everything that I see.

At the present time the engine is factory stock and has a lot of miles on it and is in need of a rebuild. I actually intend to replace the present engine with a 400CI small-block. The extra size will build more torque and weight is about the same. When it comes to building engines, you can spend (and waste) huge sums of money probably faster than in any other area. Be aware of people who know all there is to know about engines. Most people are just gold digging at your expense. Remember, the engine is going in an old truck, not an Indy car. There is no reason for spending countless thousands of dollars on an engine that is never going to the races. Believe it or not, there isn't a great deal of modification required to get a great running, reliable, durable engine from Chevy, Ford or Dodge.

If you have noticed, I try to avoid discussions of imported trucks altogether, for all foreign manufactures seem to change their product lines far too quickly to be of much good for this purpose. The day may come when the availability of used parts that actually work may mean the difference in having a useful vehicle or not. Many, if not most of the engine parts for Chevy, Ford and Dodge have not changed substantially in the last 30 years. This fact is not true for Toyotas. If you just have to have foreign truck or car, insure that you have sufficient spares on hand.

This brings us to another point that may or may not have been considered, so the big earthquake hits, the destruction triggers an economic collapse and you get into your vehicle and drive away to the remote spot that you either own or have staked out and you and loved ones have arrived safely. What now? It wouldn't take a huge stretch of the imagination to realize that a running vehicle is going to be a desirable item. Some safeguards should be in order to preclude others from taking the vehicle from you. Armed guards surrounding the groups' vehicles is probably not in the cards of most survival groups, you will be far too busy to be playing MP. If you are relocating to an area that is land that is owned, then perhaps a natural or man-made shelter that keeps the vehicles out of sight and safely stored would be the wisest choice. If these preparations are not possible, then some camo netting or other natural covering could be used. Bear in mind also that in the event of total breakdown there will be no further production of fossil fuels, refineries are simply too good of targets to expect them to last long. I have planned for my truck to get me to where I need to be, cover and store it, and then I plan to do without it. Also, what the government will do is anybody's guess, but it probably would not be a wise to openly flaunt vehicles or guns. Plan on moving back to the mid 1800's and using your truck to get you there.

Since the exact date of the coming doomsday is unknown, we will be using this vehicle for an undetermined time to come. There are many sources of information that relate to and will add to the base of information of your particular vehicle. You should personally do the routine maintenance and modifications yourself. If that is not possible, pay close attention to the person working on your vehicle and keep in mind that it may be you doing the work next time. Keeping a factory service manual and spare parts and supplies actually in the vehicle may be the difference between using your vehicle or not. There have been many pages written about the things that should be done in advance of a disaster or upheaval and we don't need to spend time here on

them, however, let us touch on one point briefly. In times of stress or crisis, humans tend to do what they have done previously. This is the foundation in training individuals who need to act quickly, like pilots or firefighters. If you are familiar with a given situation, odds are you will do the correct thing if you have done the exercise before. What we're talking about here is that it may be advantages to actually do the things that you would do if there were a life-threatening event.

Actually take your vehicle 4-wheeling, actually grab the wife and kids and just go for a few days. Pretend that it is the real thing - be prepared in advance. Take notes of the things that you do wrong. If your safe area is nearby, go there on long weekends. Practice being without. There are things that you need to be thinking when setting up your vehicle. There should be spare tools, parts and supplies on board your vehicle at all times.

You would absolutely be amazed at the things that I have seen that cause a vehicle to fail at an extremely remote location where your survival skills could be called into play for real.

Pay attention to your vehicle, when you look under the hood, actually look at what you see. Are the belts worn or frayed, the hoses swollen or cracked, the water pump leaking at the weep hole? Usually vehicles are not stranded by major failures unless really abused. The most common failures are broken belts, leaking or blown hoses, a fuel pump that suddenly stops after months of warning. You get the picture. Rarely does a well maintained, smoothly running vehicle instantly go silent with no warning at all. Keep simple spares on the vehicle as a matter of fact. Belts, hoses, filters, lubricants, bulbs, tire repair kits, grease, rags, hand cleaners, etc. There is a complete list of what is actually carried on board my truck later. All this should seem extreme, because it is. The funny thing is that I seldom use these spares for my truck, although it has happened. Normally, the parts and supplies are used to get another truck underway. The items that you have on your truck may be exactly the right part for my vehicle - perhaps some bartering would be in order here?

A very large part of having the ultimate survival rig is not the actual piece of equipment at all; it is being intimately familiar with the vehicle, owning it for a long period of time. Having the correct spares and supplies for the vehicle, carrying the basics like antifreeze, motor and gear oil. Many friends of mine would not own a Chevy if you gave it to them. They are die-hard Ford fans or Dodge fans or Toyota fans, whatever. All brands seem to work well if properly set up and maintained, and you need to carry specific spares for that vehicle. Check out the car or truck you have now, what is carried on board as you read this. Surely you have a spare tire, jack and lug wrench of some kind? Perhaps you have some tire sealant in a can so the wife doesn't have to change a tire along a busy freeway or a bad neighborhood? Most everyone has a few cheap tools and electrical tape to patch things up enough to get the vehicle down the road until permanent repairs can be made. The idea is to continue that process until you can be confident that there is very little that could happen that could prevent you from continuing the trip. After all, this is one journey that you really do want to make uneventfully.

I make it a point to do all routine maintenance on the truck with the tools and supplies that are already on board, if I don't have something, I make a note and have it on board later. You would be surprised at how little is required to do the simple things that seem always come up. Some things don't come up until the vehicle is used off

road for a while and things underneath get tweaked. Then carrying such things as spare front hubs, differential covers, tie rods, all manner of bolts and nuts makes perfect sense. More than once my wife has looked at an obscure broken part and said, "You have a spare for that?" "Of course, Honey, I'm a mechanic, remember?" So far so good. When you make a choice of vehicle, you should have the same confidence that there is nothing you couldn't do if you had to, after all, you might. I try to plan to be able to return to an operating condition at all times, with the possible exception of a crash, rendering the vehicle unusable. Everything else should be fixable, I hope.

REQUIREMENTS What makes a good 'bug-out' vehicle? All vehicles designated for this job would have some common characteristics. In perhaps no particular order might be: stealth, great range, simplicity, reliability, off-road capability, ability to absorb damage and continue to function, on-board communications, and be self-contained. It is beyond most of us to obtain, maintain, insure, register, and store a separate vehicle just for the sole purpose of 'bugging-out'. Perhaps if we did, the choice of vehicle would be easier. As it is, whatever vehicle is chosen must accomplish more than one mission and that always involves compromise.

Several of the criteria would be met simply by choosing a vehicle that already meets them. Heavy, American-made 4-wheel drive pickup trucks and SUV's answer most of the requirements without modification. They can absorb some damage and continue to operate, can operate off of the pavement when required, can carry a sizable load in addition to the family members. Choosing a non-descript paint job, a common vehicle type, restricting the modifications to those not apparent to the average guy will go a long way to ensuring the vehicle will be able to fulfill it's mission.

Also, the locale will play a large part in which vehicle to be chosen. In the Midwest or Southern states, a One-ton GMC crew cab dually 4x4 pickup will not even raise an eyebrow. A camo paint job won't really get extra attention in some rural areas. If you live in San Francisco, that same vehicle would instantly get you labeled a "survivalist whacko". But even in SF, a green Toyota SUV goes unnoticed by most everyone.

MODS You have to at some point make a choice as to a particular vehicle, or perhaps you already own what you consider to be the ultimate survival vehicle and wonder how to make it better. According to popular off-road magazines, a stock 4-wheel drive vehicle will make it on about 85% of the trails maintained for them. To get the vehicle up more of the trails, modifications are required, but not as much as you might expect.

- 1) The first mod would be the replacement of stock tires with tires *slightly* larger but with more aggressive tread. Perhaps 31-33" diameter. The reason that you don't need and really can't use monster tires (40-44") is that many more mods are required to adequately use them. More on that later.
- 2) Next of the list would be traction aiding differentials. Some already come with a limited-slip rear differential, few if any come with true lockers front and rear.
- 3) The next would be lower gears in the transfer case. Most 4WD's come with a 2:1 or so and all could use a 4:1 or lower.
- 4) The next would be beefy skid plates that are suitable to the vehicle. Some vehicles, especially Jeep products have excellent plates from the factory. Others have little or none.

- 5) Next would be a small suspension lift, perhaps 2-4". And that is all. If you were building a truck for off-road only, you may elect to go higher but it will not result conquering every obstacle. All lifting of the vehicle will cause the vehicle to become more unstable and increase the aerodynamic drag. Each inch a vehicle is lifted is estimated to increase drag about 3%. So a 10" lift would increase drag (and fuel consumption) about 30%. Not good for range and limits the vehicle in normal service.

These modifications will not be obvious to the average guy and will make your vehicle much more capable off the paved roads. There are other things that need to be done to your vehicle to adapt it to the job of 'bugging-out'

- 6) Additional fuel tanks, if possible, to increase range. It should go without saying that never allowing the fuel tank to go below half-full is contrary to the mission. Keeping some portable fuel cans in the garage or other safe storage may be helpful.
- 7) Communication equipment. Cell phones can become unusable in a moment's notice. Even natural occurrences such as hurricanes and tornadoes can render cell phones inoperative. Plan on some alternative communications. CB radio may provide some short-range comms, as will FRS radios. For anything other than very short range, Amateur radio gear becomes necessary. If you are serious about survival, communications become paramount and the only practical solution is Amateur radio. Keeping a short-wave receiver and scanner in the vehicle is recommended.
- 8) EMP protection if you are concerned with a possible Nuclear attack. This is not a lost cause as some may have you believe. The aircraft that dropped the only nukes used in combat had radial engines using magnetos for ignition. They were properly shielded and suffered no harm. EMP is a funny animal and should be studied if you are concerned. Many feel that a post-nuke world is not worth surviving to so they ignore the problem. Others rely upon Diesel engines that are not affected by EMP. Others carry spares of items that may be affected in ammo cans that will provide shielding and plan on changing components that may fail when exposed to large amounts of EMP.
- 9) Built-in storage areas to contain spares for the vehicle and supplies that may be left on board the 'bug-out' vehicle at all times. A list follows of items carried on my personal vehicle.



This picture shows the air compressor installation. The compressor was originally installed on a Chevy van as an aftermarket air conditioner installation.; The compressor was manufactured by Borg-Warner and is very common on older Ford vehicles and numerous aftermarket installations. The benefit of using this type of compressor is that the design has separate places for compression and lubrication, the same basic design as any piston engine. Other air conditioning compressors use the oil suspended in the refrigerant to provide lubrication for the compressor. While you can use this type, the life expectancy is very limited. The upper (suction) hose for the compressor in the photo is routed to the carb side of the air filter; this allows the compressor to always compress filtered air, hopefully extending the life of the compressor. Notice the radiator hose routed behind the compressor, which is standard for this installation in the van. The lower (discharge) hose of the compressor is connected to a TEE fitting where forward is the pressure switch, the same switch found on most all electric air compressors, and aft it is routed to the storage tank mounted between the frame above the driveshaft. From the storage tank, the air is routed in the frame to the rear left fender where there is a standard pressure gauge and female quick-disconnect outlet. The same outlet is found on most all industrial, shop and home compressed air systems. All of the components were found at common outlets, the only difficult piece to find was the pressure switch and that was located a Grangers Industrial Supply and it only cost \$30.



This picture shows the actual installation of the female disconnect and the pressure gauge. This part could be located anywhere that the owner chooses, this just happened to be a convenient place to mount it. Also notice that the taillights have been changed to this type, which originally came in a '69 International truck or Scout. It is a very common and fairly straightforward modification. This removes the stock add-on light assembly, which frequently receives damage when off-roading.



These photographs show other vehicles that would make great off-road ready “bug-out” vehicles. The upper picture shows a mid-70’s Chevy Blazer (K-5). These were very popular and shared most parts with the light truck line at General Motors. They are relatively cheap to buy and maintain and can be modified easily with factory parts. The replacement of the drivetrain components with one-ton units yields a vehicle, which is virtually unbreakable and unstoppable. The Blazer will carry five adults and about 700 pounds of supplies and the short wheelbase makes for great off-road capabilities. Also, Blazers are so common that no one would notice anything out of the ordinary, even when equipped with the one-ton drivetrain and winch. Also, I understand that these all came equipped with the fuel tank in the rear frame area but there is enough room along the frame rails that standard 16 gal pickup truck fuel tanks can be installed. I have not performed this myself, so check it out.

The lower picture is of course the Chevy Suburban. This vehicle also shares all major components with it’s GM brothers but the body has been lengthened to hold nine adults comfortably. The suspension will carry a lot of weight and it also will go off-road just fine but the increased wheelbase limits the capabilities somewhat. This vehicle came stock with a 40 gal fuel tank and has room underneath for additional tanks if required. Both these vehicles can be expected to get about 12-14 mpg in town and about 15-18 when driven conservatively on the highway (55-60mph).



For all you Mopar fans here is a picture of what is probably the ultimate Mopar “bug-out” vehicle, the Dodge Ramcharger. These are also common although nowhere near as common as Blazers. There are many people who believe that the engineering has always been superior at Chrysler and that is probably true but you have to weigh that fact (maybe) against the availability of parts for GM vehicles. Ramchargers can also be refitted with heavy-duty drivetrains, suspensions, winches and all other common modifications. The only drawback is that the parts are harder to find and cost substantially more. Also, it may be difficult to find used parts that will work from wrecking yards or wherever.

The lower photo is an early photo of the author’s truck. The short wheelbase truck is very similar to the Blazer, but it has a little more variety in the way it is used in everyday service. I find it easier to use for the types of things that I do: camping, hunting, fishing, hauling all kinds of stuff (some of which you would not want inside of ANY vehicle). I could use a Blazer or Suburban but this vehicle was available for the price I wanted to pay (\$1000). These trucks came from the factory with pretty good suspension and drivetrains; however, they are easily modified when required. If you look carefully you can see the extra fuel filler cap on the rear of the right rear fender. Most people never notice this and in fact there was a factory option for the aft tank in 1973-74 model years. You just have to be careful when you refuel that people don’t notice that you’ve just loaded over 60 gallons of gas. The body is pretty well gone but that in itself does not affect the mission of the vehicle. However, I will be replacing the body panels and giving it a non-descript paint job shortly.



Here is the installed fuel tank under the bed of the author's truck. This is a standard installation in a Blazer or Suburban and was optional in 1973-74. This is where the spare tire normally goes, the tire is now mounted in the bed.



This is the air compressor pressure switch mounted along side the radiator. Second battery removed for clarity.

FUEL SYSTEM WITH 40 GAL AUX TANK

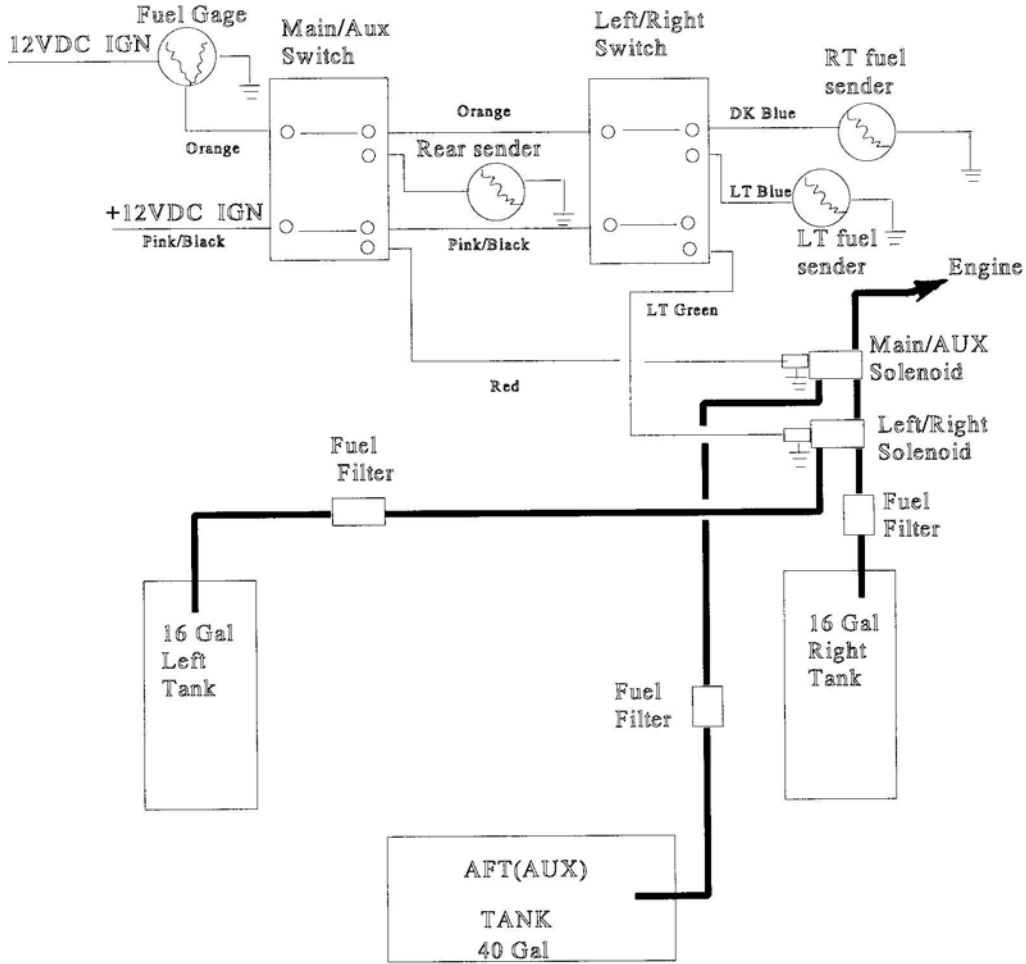

SELECTOR SWITCHES (FACTORY)

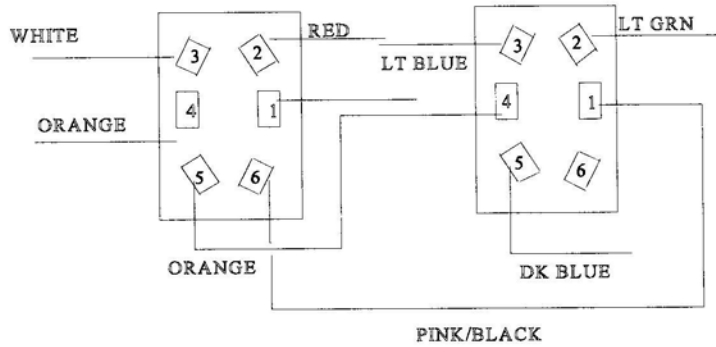

WIRE COLORS SHOWN ARE ORIGINAL CHEVROLET FACTORY WIRES



The pictures on the previous page show several views of a Hummer. This is the vehicle that everyone in Hollywierd just has to own. *They are to DIE for.* The Hummer is regarded as the ultimate off-road vehicle. The Army uses them, TV series and movies are full of them, they must be the best, right? Well, not exactly. The very things that make them the ultimate off-road vehicle actually work against them for the “bug-out” mission. They have a lot of characteristics working against them actually. First of all is price. About \$105,000 and counting. A little too steep for most of us. Even if you could afford this beast, you still haven’t made a good choice. The Hummer gets about 8 mpg, it comes equipped with a 23-gallon fuel tank and doesn’t have room for any more. Range – 170 miles. Big problem, where are you going to find gas every 150 miles or so? Also, one of the pictures shows (badly) a view of the underside of the Hummer. Ever seen anything like it? No? There is good reason for that, there has never been a vehicle designed like this before. All of the suspension, drivetrain, body and accessories are one of a kind. That is a fatal flaw for any vehicle suitable for this mission. If you need any part for a Hummer, there are two places to get one, from the factory (or dealer) or from you neighbor’s Hummer. I can’t imagine Hummer dealers being able to weather a total economic collapse and my neighbors can’t afford Hummers. Great vehicles to own if you can afford them and you have a Chevy truck just in case...

The following is a list of the items that are normally carried on board the pick-up at all times.

A fairly complete set a hand tools
 Six quarts of motor oil (AC Delco)
 Four quarts of synthetic gear oil
 One gallon of windshield solvent
 High lift jack (sheep header jack, Hi-Lift Brand)
 Spare tire of the same size installed on the truck
 Two quarts of automatic transmission fluid (for power steering)
 Sections of each size of heater hose, fuel hose, vacuum hose
 Long pieces of various gauges of electrical wire
 Selection of electrical connectors and ty-raps
 Electrical tape, duct tape, longest ignition lead (from last change)
 Hand-type wood saw, axe, compact and full size shovel
 Spare fuel pump, water pump, thermostat, upper and lower radiator hose
 Complete set of belts, oil filter and fuel filters
 Air hose for compressor, impact wrench for lug nuts, air chuck for filling tires, tire spoons
 Spare rear drive shaft (inside rear bumper)
 Spare front driveshaft, short side drive axle, differential cover for front axle, gaskets for both differential covers
 Full-time hub gears and covers for front axles
 Backpack size survival gear (requires separate list)
 Four two-liter bottles of bottled water
 Tire puncture repair kit, factory jack and crank rod
 Three cell Mag-light, backup flashlight
 Tools specific to this vehicle, special socket for front hubs, oil filter wrench, grease gun
 Regular coveralls, insulated coveralls, cold weather gear
 Propane torch, solder and flux (to repair radiator)
 Spare bulbs (stop, turn, and interior)
 Spare universal joint of each size on truck
 Four foot section of one inch angle iron
 Factory and Haynes service manuals
 Hack saw, kit for winch (tree saver, pulley block, ect.)
 Spare spark plugs, cap and rotor on spare distributor
 Ratchet type tie down straps, fifty feet of small rope
 Spare spindle for front axle, complete with bearings and seals
 Shop rags, hand cleaner, WD-40, Teflon tape, wire brush, etc.

This is pretty much what I carry, but it is probably not really complete, I'm sure I've let some stuff out. These items are carried in a tool box that straddles the bed, some in boxes under the hood, and some behind or under the seat. This does add some weight to the truck but not as much as a full fuel load. Use your experience to determine what is needed on your rig. Drive safe.



ULTIMATE SURVIVAL VEHICLE PART II

As I have mentioned earlier, I am also an aircraft mechanic. There is a license required for this and there are also several grades of Pilot licenses. For those who have considered the possibility that ANY on road or even off road travel may become impossible, there exists another route out of town. Perhaps the easiest way out of a disaster area is by air. I do not mean to buy a ticket on American, but literally grab a plane and go. When you start adding up the costs of being prepared, they can quickly reach a staggering amount. How many readers out there own a \$20,000 sport utility? Paid more? \$30,000, \$40,000, more? Shame on you.

For about \$2500, you can earn your Private Pilot rating. As its name suggests, it is a license that allows you to use an aircraft you have been checked out in, for any legal purpose.

Those crammed, slow-moving, dangerous main roads got you down? No problem, just grab your wife and kids and toss them in an airplane and off you go, above and beyond where any land vehicle can go. This has the potential to be the ultimate getaway vehicle. I can hear you thinking, this guy was all right talking about modifying Chevy trucks, but this is way out there.

Bear with me for a moment, remember I said that swapping in a one-ton drive train would cost \$3000? I came up with that figure providing I did all the work myself. How many people are willing to undertake such a project? I have no clue, but I would imagine that many folks would rather pay someone else to do the work, driving the cost up much higher. So, for the cost of some modification, or another vehicle, or whatever, you could become a rated pilot. I have also given a bit of flight instruction over the years and can say with a straight face that there are not many people that cannot learn to fly. After all, the goal here is not to be a Captain of a 747 flying in bad weather into Hong Kong, the goal is to fly a Cessna out of a danger area into a remote strip that has been explored and approved long ago.

The gears in your heads are making so much noise that my computer is getting static.

Where is this guy coming from? I live from paycheck to paycheck and there just isn't any left over for flying lessons for Christ's sake! Okay, okay, not everyone has the resources to go out and buy a new airplane (\$120,000 and up) and earn an Airline Transport Pilot Rating (\$45,000).

So, let's get a little more realistic. Instead of driving a \$25,000 car or sport ute, why not drive a paid-for \$1000 Honda? After all, the car is only expected to get you to the nearest airport.

Then of course the \$2500 required to earn the Private license does not have to be paid all at once.

Should you buy an airplane, or rent? There are entire books written on the subject and none can answer the question for you. In this situation, it is a toss up. If you own the airplane, then you will not face any moral dilemma when the time comes for its most important use. If you rent, you have access to the aircraft without the capital expense, but you may feel guilty taking an airplane out of town when you have no intention of bringing it back. This may also include legal aspects.

There is another side to this equation, it is possible to have your cake and eat it too. How about buying the airplane and then leasing it back to the FBO (Fixed Based Operator) to make the payments, provide maintenance, and insurance coverage? In years gone past, this was a little known secret, and a somewhat lucrative business venture. The tables have turned over the years and this is no longer a profitable enterprise but it will greatly offset or perhaps even completely pay for the aircraft. Check with the local FBO's to see how receptive they are to the idea. How much does this madness cost? A used Cessna 172, the most popular light airplane in the world, and the perfect machine for this mission, will run about \$35,000. You will be required to pay a 20% down, perhaps some initial maintenance, and other miscellaneous costs. Figure \$10,000 and you too can own an airplane. Use this airplane to learn to fly in, and the cost of earning a Private license drops considerably. None of this information is new, by the way. This same conversation has been going on since Orville and Wilbur. Once you earn your pilot's rating, you will have to fly on a regular basis to stay current. The law spells out the minimums but they are way below what is actually required in the real world. You should plan on actually flying at least twice a month for about one and a half hours. That is three hours a month and about \$60 per hour in a rented airplane. Not cheap. However if it is your airplane, the cost is equal to fuel and maintenance, about \$25 per hour. Much easier.

Okay you are saying, perhaps this is feasible after all. What can I expect for performance from this light aircraft? Well, welcome to the land of BS, more commonly known as aviation. The truth is that the airplane is fragile, slow, and very boring. This is how light aircraft are designed, and how they are maintained (by law). However, the capabilities will surprise those people not aware of the performance. For example, the Cessna 172 actually flies at 105 knots. Once again forget the BS, that is about 120 mph in a straight line. The engine burns about eight gallons of fuel per hour, and most 172's have 35 gallon fuel capacity (some have 50). So using simple math, you can go about 500 miles with the small tanks and about 700 miles with the big tanks. That is miles in a straight line, over obstacles, over water, over whatever. No cops, no feds, no National Guards, no nothing. Just get in, fire it up and go. There is a distinct advantage to operating out of a non-controlled airfield for this mission. (An uncontrolled field is one without an operating control tower, they are very common)

The Cessna requires a very small strip to operate into and out of. You will have to refer to the manufactures operating guides for the specific numbers but I have personally taken off in 700' in calm wind and have landed in 300' without abusing the airplane. This does not include clearance for terrain or trees. Do not expect your airplane to fly through trees, buildings, billboards or other Hollywood film stunts. Normally speaking, if the airplane does not do what it was designed to, heavy destruction and loss of life will occur. You will have all the graphic details drilled into you during your pilot training. An aircraft is designed to be operated within a very specific set of parameters; this is called the aircraft's envelope. The aircraft can only operate within it's own envelope. A Cessna is not an F-16 (fighter) nor is it a C-130 (heavy cargo). All aircraft are operated well inside of the envelope if a long and healthy life is to be expected. If you try to fly the airplane too slowly, it will stall and you may not have enough altitude to recover. If you fly too fast, the forces on the tail will cause the elevators or horizontal stabilizers to leave the airframe, in this case, the altitude has very little effect on the size of the smoking hole you will leave in the ground. There is similar news about G-loading, maneuvers, and rough field take-offs and landings.

With all that said, a Cessna 172 would take you and the wife, two medium kids, a small amount of gear (50-100lbs) and enough fuel to take you far away, and very quickly. So if you don't really look forward to bumper-to-bumper traffic, roadblocks, and federal officials giving orders, perhaps you should at least entertain the possibility of earning a pilots license.

Perhaps the cheapest and smartest thing to do is go to the airport, find out who gives flying lessons, and bend their ear. Leaving the survival mission out of the conversation would be advised. The books on the Private pilot rating, on the specific aircraft, and detailed charts are reasonably priced and are worth studying. Also, it has been my experience that women make great pilots, they tend to stay within the envelope and therefore live longer. The he-man approach does not work on airplanes in real life. Also, bear in mind the BS factor is rampant in aviation. Everywhere you turn, people will tell you need these instruments, those radios, this navigation aid, etc., ad nauseam.... If you stick to the basics, the total bill will be a fraction, and the airplane will not be broken when you need it the most. Also, the actual aircraft type will be subject to debate.

If you have any questions, go find an old mechanic, buy him lunch and really ask all the questions you may have. Aircraft with low wings should not be operated from unimproved runways, engines with turbo chargers or constant speed propellers will quickly bring anyone to financial ruin. Advanced avionics are really only required for corporate or airline use. Keep it simple and you will have fun and can count on using this machine to get your family to safety.

Just a few words about survival...

There are no set guidelines that can guarantee any one persons' survival in all adverse situations. History has shown that any person can improve his or her chances of survival but there are no guarantees. Part of preparing for or trying to improve the odds of survival should be a study of actual cases of people triumphing over unbelievable circumstances to tell their stories to their grandchildren.

History shows us that women survive in a higher ratio than do men. I'm not sure why and neither do the women. Keeping calm and not giving in to panic has to be a large factor involved in situations that there can be no preparation for. The ability to think clearly under extreme pressure is either a gift or learned by repeated exposure to stressful situations.

There are generally just four basic rules for survival:

- 1) You must possess the knowledge required for the situation and mentally be prepared to use this knowledge.
- 2) You must be physically able to perform the tasks that may be required in the situation where some, many, most or all persons may perish.
- 3) You must have the raw materials required to meet the situation at hand. These materials will vary with the situation that you may be faced with.
- 4) You must be willing and able to defend yourself and your family, your possessions and supplies against those who will be fighting for their lives to take them from you.

No one truly hopes the present situation will degrade to this level. There is no indication that the situation will get this bad today, tomorrow, next week or next month. There is evidence that the situation will reach a critical stage at some time in the near future. The planet that we all depend upon simply cannot support the levels of population that are currently being maintained. One year or perhaps two of drought conditions throughout the grain belts of America and Russia and the results would be catastrophic. The collapse of the economy is only one real disaster away. There are dozens of situations that could lead to chaos and turmoil and sooner or later, one of them will.

With all of this in mind, how does one improve the odds that you and your family will be among those who will live on? The first thing you can do is get the education and training that is required to meet any situation that you will likely find yourself. There are survival schools and tactical weapons schools and all manner of places to get training that you need or perhaps just to sharpen skills that you already possess.

Next, simply get in shape. There is simply no excuse for being obese or really a major couch potato. You must walk or run every day. You must build muscles that you don't use in your office. Lift weights, use heavy hands, martial arts, simple exercises, whatever. The idea is that you should be able at any time to flee or fight. PERIOD. You should be able physically and mentally to do either or both. Your life and your family's safety may very well depend on your skills and conditioning. Experts suggest aerobic training three times a week, resistance (weight) training twice a week. Don't have the

time? MAKE IT. Your family deserves the best possible chance you can provide. I'm not suggesting that you are in condition for twelve rounds with Iron Mike or an alley battle with Jackie Chan, just what needs to be done. Martial arts classes are cheap and a good way to get in shape and practice your evasive moves.

Stashing food and supplies is the most common approach to survival preparedness but is the least likely to be of any help. I was in a bad wreck once and wound up with a bunch of broken bones and my jaws wired shut for two and a half months. My weight went from 200 lb. to 120 lb., but I learned that a healthy person can go for a very long time without eating anything and even longer if there is any food at all to eat. Water is another story. The average person who does not exert himself or herself can only live for three days in the desert. Perhaps five days in a cool forest so be careful when it comes to watching how much to drink. Women and children can usually last longer than adult men due in part to less surface area and less activity.

Now, how to protect those carefully prepared supplies? Once again, entire books have been written on this subject so I'll just add my two cents. Unimproved land is cheap, between \$200 and \$1000 per acre depending on the part of the country that you live. Look for land that does not have electrical power anywhere near the place. Real estate that has power, phone, whatever (paved roads?) will send the price through the ceiling. Stick to the basics, when the stuff hits the fan, you won't have power, phones, water, sewer and the roads won't be safe anyway.

Once you find your place, then it is a simple matter to hide, bury, store however you think best. I will say here that the fewer people that know of your hideaway and your storage plans, the fewer people you will have to fight to keep it. The best situation would be to own some land that has no access at all from the ground. You can use a light plane, boat, or perhaps a tough four-wheel drive to get you there.

The best advice I can give is to use your land and live just as though you were not going back to the city. You will find in short order what is actually required and what is not. It will amaze you (and your wife) how little you need to actually get by on a long-term basis. If possible, plant the things you like to eat now so that they will be growing naturally when the time comes that you need them. There will be an acute shortage of animals to eat when they are the only food source for the people fleeing the city.

Some people advocate setting up survival groups, people who get together for the sole purpose of combining skills for survival purposes. This is fine, BUT, remember that the more people who are involved, the greater the risk that something will go terribly wrong. Remember that in a real survival situation, the lives of another man's family are just as important as the lives of your own. I prefer to keep the group as small as practical and as close to all family as possible. I don't relish the idea that someone would kill my family so that his would survive. I know that this is common and necessary in nature, but I would prefer to avoid the situation altogether.

Also, the further you are from any type of road, the better it will be. It will definitely make for a pain to use the land before the need arises, but it will insulate you and your family from gangs out 'hunting' after the collapse. If you have a light plane, it can be a very nice way to get the family out of the city for some peace and quiet. A creek bed may be just the ticket for you four-wheelers out there that want to go where no one will follow. Use your imagination and keep it quiet. Your neighbors notice far more than you might think. Whether or not you own firearms, how often you go

'camping', the groups of camo painted four-wheelers in the street. This information will probably go unused until they really need something you have, or worse, when they tell someone they meet, even innocently, about their 'survivalist' neighbor who has a retreat 'up north'. The less information people have and the fewer number of people know, the better it is for you and your family.

I personally have a motor mouth and I depend upon my wife to give me a firm nudge when I have spilled enough beans. Over the years, I have learned to keep conversations light and not give away too many 'trade secrets'. There are few people who know who I am and what I really think. After all, you can use cash (for now) and no one has to know anything. When I buy gold, ammunition, guns or groceries I don't say any more than I have to and I always pay in cash. No use making it any easier for those persons who would really like to know just what you have hidden away.

If you want a picture of the future, use history. Think of what happened in Germany before WWII, the gun controls, secret police, people disappearing at night, neighbors telling on neighbors. China, Russia, Africa, Vietnam. The list could go on and on. The point is that the mechanism works very much the same in all cases. Lax enforcement of the law, escalating crime preceding tougher laws and reduced freedoms, then gun controls, then outright banning of firearm ownership by private citizens. Then come the house-to-house searches at night, usually by a tip from a neighbor. Finding weapons results in the owner residing at the bottom of a trench with a small hole in the back of the head.

Sound unbelievable? It couldn't happen here! THIS IS AMERICA! It always sounds unbelievable, that is why it happens over and over. People just can't understand how it got like this ALL OF A SUDDEN. It has been happening for years, people have been trying (in vain) to make ordinary people listen, but as you know, the average Joe hasn't got a clue until the axe hits HIS neck. Remember, every time a law is passed, that is freedom that you personally have lost, never to regain. Once power is given to the government, only a revolution will take it back.

An Afterword...

This article was originally written back in 1994 and was sold in a Survival magazine that is no longer around. This is now late in 2002 and things are certainly no better. The Twin Towers in Lower Manhattan are a memory along with 3000 lives.

The Government is out of control. Not only can it not control the persons who would do us harm, they cannot even protect themselves. There were successful Anthrax attacks on the CIA!

The CIA! These are the folks who are supposed to see all and know all. They don't have a clue.

The response from the Government was 180° out as usual. Instead of calling all citizens to arms, as their founding fathers would have done, they stripped the citizens of their rights by passing the infamous 'PATRIOT' act. Which has absolutely no redeeming qualities whatsoever. 257 pages of garbage none of the signers even cared to read. Your 4th and 10th amendments are now trash.

The only appropriate response from our Commander-in-Chief should have been to close our borders. NOW. Prevent any Muslim male between the ages of 17-50 from entering and ejecting all Muslim males not yet citizens or with permanent status. Any Muslim male not here on a permanent Visa should be escorted to the airport, let Uncle Sam buy him a ticket anywhere he wants to go.

The Internet is far wider reaching than I would have ever predicted. It is a mixed blessing. It allows enlightened folks to share information and ideas without censure. ***It also allows the Government to monitor and collect all that information.***

I have been busy since 1994. I took up flying in a big way. A really big way. I ended up flying 747's into Hong Kong. I visited countries I had never heard of, talked to people I never would have met. Worked with men who were intelligent and gifted.

All of which brought me back to where I started. Some diaper-heads with huge cahones and an axe to grind slammed some airliners into some buildings. So what. I could teach an 8 year old how to do that. They screwed that up and the only response our government has is *of course* to punish the citizens. **Not the perpetrators.**

Same old song.

So the words I wrote nearly 10 years ago are still valid. Not surprising as history has a cycle like everything else in life. We just happen to be in the downward slope. How bad will it get? Read history and find out.

I have decided to include a section of reference material. Book lists, movie lists, URL's,

Survival kits you can make yourself... stuff like that. Use it at your discretion.

I have not read every one of the books listed although I have read a lot of them. It would be nice if the local Public library had these on the shelves, but that isn't PC.

KNOW YOURSELF

Holy Bible

"The Merck Manual" ISBN 0-911-910-87-5

"Grays Anatomy" (The new one, not the classic)

"US Army Special Forces Medical Handbook" ST 31-91B

"Where There is No Dentist"

"Where There is No Doctor"

"A Pictorial Handbook of Anatomy and Physiology" Dr James Bevan

KNOW HISTORY

"The Gulag Archipelago" Aleksandr Solzhenitsyn

"Jim Bridger – Mountain Man" Stanley Vestal

"The Tunnels of Cu Chi" Tom Mangold & John Penycate

"Gone Native" Alan G. Cornett

"Marine Sniper" Charles Henderson

"Riverine" Don Sheppard

"The History of the World (in Two Hundred and Forty Pages)" Rene Sedillot

"War in the shadows" by Che Quevera

"Blackhawk Down" by Mark Bowden. Perhaps the best non-fiction, real-life urban warfare book ever written.

"A People's History of the United States 1492-Present", Howard Zinn ISBN 0-06-093731-9.

Co.Atch "H" by Sam Watkins

"When in the Course of Human Events" by Charles Adams

"Emancipating Slaves, Enslaving Free Men: A History of the American Civil War

by Jeffrey R. Hummel

"Guns of the South" by Harry Turtledove

"The Camp of the Saints" Jean Raspail Translated by Norman Shapiro

RESISTANCE

"Total Resistance"

"Guerrilla's in the Mist "

"101 Things to do Until the Revolution" Claire Wolfe

WEAPONS

"Boston's Gun Bible". " Boston T. Party

“Survival Guns” Mel Tappan

COMMUNICATIONS

“Now You’re Talking” ARRL

SURVIVAL

“Nuclear War Survival Skills” Even if you don't want to survive a nuclear war, this book is jammed packed with do it yourself survival idea's. From food, water, shelter, lighting and sanitation.

“Surviving Y2K” Boston T. Party

“The Indian How Book” Arthur C Parker

“Camping and Wilderness Survival” Paul Tawell

“Outdoor Survival Skills” Larry Dean Olsen.

“Wilderness Living and Survival Skills” by John and Jeri McPherson.

“Northern Bushcraft” Mors Kochanski.

FICTION

“Six ways in & twelve ways out” .

“First Angel”, very good

“Alas, Babylon” Pat Frank

“FootFall” by Pournelle and Niven. It's about a war with aliens but the survival scenario's are very good.

“Iron & Wolf.” My favorite. This is about one man surviving on his own with a wolf and later a girl.

“1984” George Orwell

“Animal Farm” George Orwell

“Fahrenheit 451” Ray Bradbury

“The Postman”

“Earth Abides”

“The Minuteman Handbook

“The Devil's Advocate” by Taylor Caldwell.

“Malevil” by Robert Merle

“Long Voyage Back” Luke Rhinehart

“Things Fall Apart”

“Aftermath”

“Farnham's Freehold” R.A Bob Heinlein

“Tunnel in the Sky” R.A Bob Heinlein

“Between Planets” R.A Bob Heinlein

“ Rocket Ship Galileo” R.A Bob Heinlein

“None Dare Call It Treason” John Stormer

“Unintended Consequences” John Ross

“Lucifer's Hammer” Larry Niven and Jerry Pournelle

“Patriots: Surviving the Coming Collapse” James Wesley Rawles

“Death Wind” William C. Heine.

“Extraordinary Popular Delusions and the Madness of Crowds” Joseph De La Vega

KNOW THE ENEMY

“Mein Kamph” Adolf Hitler

“It Takes a Village” Hillary Rodham Clinton

“The Communist Manifesto” Karl Marx & Friedrich Engels

“New World Order” William T. Still

“In the Absence of the Sacred” Jerry Mander

“Four Arguments for the Elimination of Television” Jerry Mander

MILITARY TRAINING

“The Ulitmate Sniper”, by Maj. John L Plaster. A huge volume, but at least it's a paperback.

“Combat Leader's Field Guide”, by Brett A Stoneberger (12th ed).

“Special Forces Guerrilla Warfare Manual”, by Scott Wimberley.

“Ranger Handbook” (SH 21-76, July 1992).

“Engineer Field Data” (FM 5-34). Same copy I had when I was 12B10.

“The Soldier's Basic combat Training Handbook” (PAM 350-43). Same copy I was issued in Basic.

“Soldier's Handbook for Individual Operations & Survival in Cold Weather Areas” (TC 21-3). **“Survival”** (FM 21-76).

“The Art of War” Sun Tzu

COUNTRY LIVING

Kurt Saxon's series, **The Survivor**, have lots of useful information in them, as well as lots of entertainment value.

Backyard Livestock Raising

Basic Butchering of Livestock

Cottage Water Systems

Home Meat Curing Guide

Keeping Livestock Healthy

Root Cellaring

The Ball Blue Book

The Pill

“Root Cellaring” Mike and Nancy Bubel

“Five Acres and Independence” M.G. Kains

“Basic Country Skills” John and Martha Storey

“Country Life” Paul Heiney

KNOW YOUR COUNTRY

“The Anti-Federalist Papers” ISBN 0-451-62525-0

“The Federalist Papers” Hamilton-Madison-Jay

“Great Stories of the American Revolution” Webb Garrison
“The Creature from Jekyll Island” G.Edward Griffin
“Second Amendment Primer” Les Adams
“The Meeting” Keith Whitney
“Secrets of the Temple” William Greider
“Rights of Man” Thomas Paine
US Constitution, Bill of Rights

Recommended reading for US Marine Corp Personnel

The Marine Corps Heritage Section

A Marine Named Mitch, Paige
U.S. Marines: 1775-1975, Simmons
Battle Cry, Uris
Fix Bayonets!, Thomason
Strong Men Armed, Leckie
The Right Kind of War, McCormick
The US Marine Corps Story, Moskin
Tarawa, Sherrod
Iwo Jima, Legacy of Valor, Ross
Flights of Passage, Hynes
Unaccustomed to Fear, Willock
Breakout, Russ
First to Fight, Krulak
Semper Fidelis, Millett
With the Old Breed, Sledge
Once a Legend, Hoffman
Fortunate Son, Puller
Reminiscences of a Marine, LeJeune
Chosin, Hammel
In many a Strife, Millett
Once A Marine, Vandegrift
The Marine Corps' Search for a Mission: 1880-1898
LeJeune, Bartlett
Maverick Marine, Schmidt
No Bended Knee, Twining

Leadership, Memoir, and Biography Section

A Message to Garcia, Hubbard
Fields of Fire, Webb

Battle Leadership, Von Schell
Rifleman Dodd, Forester
Marine, Davis
Uncommon Men: SgtsMaj of the Marine Corps, Chapin
Acts of War, Holmes
Challenge of Command, Nye
The Forgotten Soldier, Sajer
We Were Soldiers Once, And Young, Moore and Galloway
Three War Marine, Parry
Pegasus Bridge, Ambrose
Band of Brothers, Ambrose
Company Commander, MacDonald
Once an Eagle, Myrer
Profession of Arms, Hackett
Anatomy of Courage, Moran
Douglas Southall Greeman on Leadership, Freeman
Follow Me, Newman
Grant Takes Command, Catton
Morale: A Study of Men and Courage, Baynes
It Doesn't take a Hero, Schwarzkopf
Patton: A Genius for War, D'Este
Personal Memoirs of Ulysses S. Grant, Long
Years of MacArthur, James
The Quiet Warrior, Buell
100 Days: The Memoirs of the Falklands, Woodward
Follow Me, Newman
The General, Forester
Pershing, Smythe
Eisenhower's Lieutenants, Weigley
Nimitz, Potter
General of the Army: George C Marshall, Cray
Foundations of Moral Obligation, Brennan
Memoirs of General W.T. Sherman, Sherman
Nightingale's Song, Timberg
My American Journey, Powell

Theory, Nature, and History of War Section

Art of War, Sun Tzu
On Infantry, English and Gudmundsson
The Face of Battle, Keegan
Maneuver Warfare: An Anthology, Hooker
Gallipoli, Moorehead
For The Common Defense, Millett & Maslowski
On War, Clausewitz
Knight's Cross, Fraser
The Enlightened Soldier, White
Race to the Swift, Simpkin

Military Misfortunes, Cohan
Gates of Fire, Pressfield
What are Generals Made of, Newman
Generalship, It's Diseases and their Cures, Fuller
Guns, Germs, and Steel, Diamond

Strategy, Policy, and Civil-Military Relations Section

U.S. Constitution
Declaration of Independence, Jefferson
Strategy, Liddell Hart
The Military, Moskios
Citizen Soldiers, Ambrose
Battle Cry of Freedom, McPherson
On Strategy, Summers
Makers of Modern Strategy, Paret
George Washington and the American Military Tradition, Higginbotham
The Making of Strategy, Murray
Eagle and Sword: Federalist and the Creation of the Military Establishment in America, Kohn
The Peloponnesian War, Thucydides
The 25 Year War, Palmer
A Democracy at War, O'Neill
Military Innovation in the Interwar Period, Millett & Murray
On the Origins of War and the Preservation of Peace, Kagan
Diplomacy, Kissinger
In Retrospect, McNamara
The Best and the Brightest, Halberstram
Dereliction of Duty, McMaster

Operations, Campaigns, and Battles Section

The Bridge at Dong-Ha, Miller
Fire in the Streets, Hammel
The Buffalo Soldiers, Leckie
Tip of The Spear, Michaels
Fire in the Streets, Hammel
Grant and Lee, Fuller
The Killer Angels, Shaara
Operation Buffalo, Nolan
BlackHawk Down, Bowden
The Middle Parts of Fortune, Manning
Devil Dogs, Clark
Landscape Turned Red, Sears
The Price of Glory, Horne
The Breaking Point, Doughty
Victory at High Tide, Heini
The Easter Offensive, Turley

No Victor, No Vanquished: Yom Kippur War, O'Ballance
Phase Line Green, Warr
The War of American Independence, Higginbotham
At Dawn We Slept, Prange
Guadalcanal, The Definitive Account, Frank
Defeat into Victory, Slim
Utmost Savagery, Alexander
Eagle Against the Sun, Spector
The General's War, Gordon & Trainor
Take That Hill! Royal Marines in the Falkland War, Vaux
The Campaigns of Napoleon, Chandler
To Lose a Battle, Horne
Korean War, Ridgway
A Bridge Too Far, Ryan
A Woman at War, Moore

Doctrine, Training, and Tactics Section

Starship Troopers, Heinlein
The Defense of Duffer's Drift, Swinton
Soldier's Load, Marshall
Red Badge of Courage, Crane
Ender's Game, Card
Attacks, Rommel
Common Sense Training, Collins
Maneuver Warfare Handbook, Lind
Battle Studies, Ardant du Picq
Infantry in Battle, Lanham, C.T.
The Dynamics of Doctrine, Lupfer
Panzer Battles, Mellenthin
Defense of Hill 781, McDonough
Company Command: The Bottom Line, Meyer
Dieppe: The Shame and the Glory, Robertson
This Kind of War, Fehrenbach
Forward into Battle, Griffith
How The War Was Won, Travers
The Killing Ground, Travers
Seeds of Disaster, Doughty
Airwar in the Persian Gulf, Murray

Small Wars Section

The War of the Running Dogs, Barber
The Village, West
The Old Man's Trail, Campbell
Terrorism Leader, Laquer
War in the Shadows, Asprey
How We Won the War, Vo, Nyugen Giap
Firepower in Limited War, Scales

Guerilla Strategies, Chaliand
Small Wars Manual, NAVMC 2890
Mao Tse-Tung on Guerilla Warfare, Mao Tse-Tung
Street Without Joy, Fall
A People Numerous and Armed, Shy
Che Guevara on Guerilla Warfare, Guevara
Hell in a Very Small Place, Fall
The Army and Vietnam, Krepinevich
A Savage War of Peace, Horne
Our Great Spring Victory, Van Tien Dung
From Beirut to Jerusalem, Friedman
A Bright Shining Lie, Sheehan
Giap, MacDonald
A Savage War of Peace, Horne

"Sinews of War" Section

(Airpower, Command, Geography, Intelligence, Logistics, and Seapower)

American Gunboat Diplomacy, Hagan
Price of Admiralty, Keegan
US Marines and Amphibious War, Isely & Crowl
History of US Military Logistics, Peppers
Battle for the Falklands, Hastings
Airpower & Maneuver Warfare, Van Creveld
U.S. Marine Corps Aviation: 1912-Present, Mersky
History of Marine Corps Aviation in WWII, Sherrod
Command in War, Van Creveld
Supplying War, Van Creveld
Moving Mountains, Pagonis
Ultra in the West: The Normandy Campaign, 1944-1945, Bennett
Luftwaffe, Murray
Price of Admiralty, Keegan
Clashes -- Air Combat Over North Vietnam, Michely
War Secrets in the Ether, Flicke
Logistics in the National Defense, Eccles
Rise and Fall of the Great Powers, Kennedy

Some interesting quotes...

"And now, Almighty Father, if it is Thy holy will that we shall obtain a place and name among the nations of the earth, grant that we may be enabled to show our gratitude for Thy goodness by our endeavors to fear and obey Thee. Bless us with thy wisdom in our counsels, success in battle, and let our victories be tempered with humanity. Endow, also, our enemies with enlightened minds, that they become sensible of their injustice, and willing to restore our liberty and peace. Grant the petition of Thy servant, for the sake of whom Thou hast called Thy beloved Son; nevertheless, not my will, but Thine be done." -----**George Washington** (As always Georgie had a great relationship with FATHER!)

"The Constitution is not an instrument for the government to restrain the people, it is an instrument for the people to restrain the government -- lest it come to dominate our lives and interests." ----- **Patrick Henry**

A wise decision, that gives you something to think about fifty years later..... In 1960, Robert Menard was a Commander aboard the USS Constellation when he was part of a meeting between United States Navy personnel and their counterparts in the Japanese Defense Forces. Fifteen years had passed since VJ day, most of those at the meeting were WWII veterans, and men who had fought each other to the death at sea were now comrades in battle who could confide in one another. Someone at the table asked a Japanese admiral why, with the Pacific Fleet devastated at Pearl Harbor and the mainland US forces in what Japan had to know was a pathetic state of unreadiness, Japan had not simply invaded the West Coast. Commander Menard would never forget the crafty look on the Japanese commander's face as he frankly answered the question. "You are right", he told the Americans. "We did indeed know much about your preparedness. We knew that probably every second home in your country contained firearms. We knew that your country actually had state championships for private citizens shooting military rifles. We were not fools to set foot in such quicksand." (This is a good example as to why our Second Amendment - God given Rights are so IMPORTANT and why the Elite Scumbags and their Prostiticians are trying the full court press to demolish it, because WE cannot EVER be slaves as long as we are ARMED TO THE TEETH.... God Bless America....)

It is well enough that people of the nation do not understand our banking and monetary system, for if they did, I believe that there would be a revolution before morning." -----**Henry Ford**

It is natural for man to indulge in the illusions of hope. We are apt to shut our eyes against a painful truth, and listen to the song of that siren till she transforms us into beasts. Is this the part of wise men, engaged in a great and arduous struggle for liberty? Are we disposed to be the number of those who, having eyes, see not, and having ears, hear not, the things which so nearly concern their temporal salvation? For my part, whatever anguish of spirit it may cost, I am willing to know the whole truth; to know the worst, and to provide for it. --**Patrick Henry**

Those who profess to favor freedom, and yet depreciate agitation, are men who want crops without plowing up the ground. They want rain without thunder and lightning. They want the ocean without the awful roar of its waters. This struggle may be a moral one; or it may be a physical one; or it may be both moral and physical; but it must be a struggle! Power concedes nothing without a demand. It never did, and it never will. Find out just what people will submit to, and you have found out the exact amount of injustice and wrong which will be imposed upon them; and these will continue until they are resisted with either words or blows, or with both. *The limits of tyrants are prescribed by the endurance of those whom they oppress.*" -----**Frederick Douglass**, August 4, 1857

"If you will not fight for the right when you can easily win without bloodshed, if you will not fight when your victory will be sure and not too costly, you may come to the moment when you will have to fight with all the odds against you and only a small chance of survival. There may even be a worse case: you may have to fight when there is no hope of victory, because it is better to perish than to live as slaves." ----- **Winston Churchill**

"If ye love wealth better than liberty, the tranquility of servitude better than the animating contest of freedom, go home from us in peace. We ask not your counsels or your arms. Crouch down and lick the hands which feed you. May your chains set lightly upon you, and may posterity forget that ye were our countrymen." -**Samuel Adams**

"Government is not reason; it is not eloquent; it is force. Like fire, it is a dangerous servant and a fearful master." - **George Washington**

"Be civil to all; sociable to many; familiar with few; friend to one; enemy to none." - **Benjamin Franklin**

"By failing to prepare, you are preparing to fail." - **Benjamin Franklin**

"The U. S. Constitution doesn't guarantee happiness, only the pursuit of it. You have to catch up with it yourself." - **Benjamin Franklin**

"Men ought either to be indulged or utterly destroyed, for if you merely offend them they take vengeance, but if you injure them greatly they are unable to retaliate, so that the injury done to a man ought to be such that vengeance cannot be feared." - **Niccolo Machiavelli**

"I refuse to join any club that would have me as a member." - **Groucho Marx**

"The only good bureaucrat is one with a pistol at his head." --**H.L. Mencken**

"Sir, we will give them the bayonet" --**Gen. Thomas J. Jackson**

"Be the change you seek." --**Gandhi**

PATRIOTS are not "*Revolutionaries*" trying to overthrow the government of the United States. PATRIOTS are "*Counter-Revolutionaries*" trying to prevent the government of the United States from overthrowing the Constitution of the United States.

I would rather be exposed to the inconveniences attending too much liberty than those attending too small a degree of it. —**Thomas Jefferson**

"Live your life that the fear of death can never enter your heart. Trouble no one about his religion...When your time comes to die, be not like those whose hearts are filled with fear of death, so when their time comes they weep and pray for a little more time to live their lives over again in a different way. Sing your death song like a hero going home...." - **Tecumseh**

"The Constitution shall never be construed to prevent the people of the United States who are peaceable citizens from keeping their own arms." - **Samuel Adams**

"I ask, sir, what is the militia? It is the whole people...To disarm the people is the best and most effectual way to enslave them. - **George Mason**

"Fire tests gold, misfortune brave men." -- **Seneca**

"Government, in its best state, is but a necessary evil; in its worst state, an intolerable one; for when we suffer, or are exposed to the same miseries by a government, which we might expect in a country without a government, our calamity is heightened by reflecting that we furnish the means by which we suffer." -- **Thomas Paine**

"Firearms stand next in importance to the Constitution itself. They are the American people's liberty teeth and keystone under independence. To ensure peace, security and happiness, the rifle and the pistol are equally indispensable. The very atmosphere of firearms everywhere restrains evil interference, they deserve a place of honor with all that is good."--- - **George Washington**

Democracy is two wolves and a lamb voting on what to have for lunch. Liberty is a well armed lamb contesting the issue!" -----**Benjamin Franklin 1759**

Corrupt the young, get them away from religion. Get them interested in sex. Make them superficial, destroy their ruggedness. Get control of all means of publicity and thereby: Get the peoples' mind off their government by focusing their attention on athletics, sexy books and plays, and other trivialities. Divide the people into hostile groups by constantly harping on controversial matters of no importance. Destroy the peoples faith in their natural leaders by holding up the latter to ridicule, contempt and obloquy. Always preach true democracy but seize power as fast and as ruthlessly as possible. Encourage government extravagance, destroy its credit, produce fear with rising prices, inflation and general discontent. Foment unnecessary strikes in vital industries, encourage civil disorders and foster a soft and lenient attitude on the part of the government towards such disorders. By specious argument cause the breakdown of the old moral virtues: honesty, sobriety, continence, faith in the pledged word, ruggedness. *Cause the registration of all firearms on some pretext, with the view of confiscating them and leaving the population defenseless.*" - **Vladimir Ilich Lenin** - Bolshevik nonRussian

"Today, we need a nation of Minutemen, who are not only prepared to take arms, but citizens who regard the preservation of freedom as the basic purpose of their daily lives, and who are willing to consciously work and sacrifice for that freedom."-----**President John F Kennedy**

The United States should get rid of its militias." -- **Joseph Stalin**, 1933 (sounds a lot like todays American Communists that infect our land)

"Germans who wish to use firearms should join the SS or the SA -- ordinary citizens don't need guns, as their having guns doesn't serve the State." - **Heinrich Himmler** (Ah the good Nazi Statist himself such words of wisdom in keeping free people slaves to the state.....)

"This year will go down in history. For the first time a nation will have complete gun registration. Our police will be more efficient and our streets safer. Other nations will follow our lead into the future!" -----
Adolf Hitler, 1935 (talk to old Jews and see if this was a really good idea)

Joseph Stalin, also noted once: "**Those who cast the votes decide nothing; those who count the votes, decide everything.**" (sounds like the VoteScam we got going on here in America with VNS Voter News Service. There is NO accountability. No Paper Ballots. Just Computers and those who program them....hmmm)

The most foolish mistake we could possibly make would be to permit the conquered Eastern peoples to have arms. History teaches that all conquerors who have allowed their subject races to carry arms have prepared their own downfall by doing so. Indeed I would go so far as to say that the underdog is a sine qua non for the overthrow of any sovereignty. So let's not have any native militia or police. German troops alone will bear the sole responsibility for the maintenance of law and order. ----- **Adolf Hitler**, April 11, 1942, in "Hitler's Table-Talk at the Fuehrer's Headquarters 1941-1942", Dr. Henry Picker, ed. (Athenaeum Verlag, Bonn, 1951) (Wow birds of a feather...both Hitler and Stalin talking the same talk... the peasants should not be allowed to be armed... they just might reset this tyranny with their GUNS...)

"No wonder Al Gore thinks he is president -- this is a most confusing time. The leading rap singer is white, the world's best golfer is black, and Bill Clinton just got back from Vietnam." --**Paul Harvey**

"I would be happy to give him [Clinton] a blow job [oral sex] just to thank him for keeping abortion legal. I think American women should be lining up with their presidential kneepads on to show their gratitude for keeping the theocracy off our backs." -----**Time contributor and former reporter Nina Burleigh** recalling what she told the Washington Post's Howard Kurtz about her feeling toward Bill Clinton, as recounted by Burleigh in the July 20, 1998 New York Observer

Republic: "a form of government in which supreme power resides in a body of citizens entitled to vote and is exercised by elected officers and representatives responsible to them and governing according to law." Websters Unabridged Dictionary

"The American people will never knowingly adopt socialism, but under the name of liberalism, they will adopt every fragment of the socialist program until one day America will be a socialist nation without ever knowing how it happened." -- **Norman Thomas, socialist** and member of the Civil Liberties Union

"The Constitution shall never be construed to prevent the people of the United States who are peaceable citizens from keeping their own arms." - **Samuel Adams**

"I ask, sir, what is the militia? It is the whole people...To disarm the people is the best and most effectual way to enslave them..." - **George Mason**

"The strength of the Constitution lies entirely in the determination of each citizen to defend it. Only if every single citizen feels duty bound to do his share in this defense are the constitutional rights secure." --**Albert Einstein**

"There is no subjugation so perfect as that which keeps the appearance of freedom, for in that way one captures volition itself." -**Rousseau**

"Liberty lies in the hearts of men and women; when it dies there, no constitution, no law, no court can save it." - **Learned Hand**

"The truth is incontrovertible. Panic may resent it; ignorance may deride it; malice may distort it; but there it is." -- **Winston Churchill**

"Still, if you will not fight for the right when you can easily win without bloodshed; if you will not fight when your victory will be sure and not too costly, you may come to the moment when you will have to fight with all the odds against you and only a precarious chance of survival. *There may be a worse case.* You may have to fight when there is no hope of victory, because it is better to perish than to live as slaves".---
Winston Churchill

"I hold concession or compromise to be fatal. If we concede an inch, concession would follow compromise, until our ranks would be so broken that effectual resistance would be impossible." --**John C. Calhoun**

"If ye love wealth better than liberty, the tranquility of servitude better than the animating contest of freedom, go home from us in peace. We ask not your counsel or arms. Crouch down and lick the hand which feeds you. May your chains set lightly upon you, and may posterity forget that ye were our countrymen." -- **Samuel Adams**

"It does not require a majority to prevail, but rather an irate, tireless minority keen to set brush fires in people's minds." --**Samuel Adams**

"...Be that as it may: it is my conviction that thereby I have rendered peace a great service and out of this conviction I decided three weeks ago to name the coming party rally the 'Party Convention of Peace.' For Germany has no intention of attacking other people. What we, however, do not want to renounce is the building up of our economic relations. We have a right thereto and I do not accept any condition from a European or a non-European statesman.

The German Reich is not only a great producer but also a gigantic consumer, just as we as a producer will be an irreplaceable trade partner, so as a consumer we are capable of honorably and fairly paying for what we consume.

We are not thinking about making war on other peoples. However, our precondition is that they leave us in peace..." --**Adolf Hitler**, April 1939

"If a Nation expects to be ignorant and free in a state of civilization, it expects what never was and never will be... If we are to guard against ignorance and remain free, it is the responsibility of every American to be informed." - **Thomas Jefferson**

Rebellion to tyrants is obedience to God." **Thomas Jefferson**

"We would like to live as we once lived, but history will not permit it."
-- **John Fitzgerald Kennedy**

"The Constitution shall never be construed to prevent the people of the United States who are peaceable citizens from keeping their own arms." - **Samuel Adams**

"I ask, sir, what is the militia? It is the whole people...To disarm the people is the best and most effectual way to enslave them..." - **George Mason**

Black Elk - I did not know then how much was ended. When I look back now from this high hill of my old age, I can still see the butchered women and children lying heaped and scattered all along the crooked gulch as plain as when I saw them with eyes still young. And I can see that something else died there in the bloody mud, and was buried in the blizzard. A people's dream died there. It was a beautiful dream....the nation's hoop is broken and scattered. There is no center any longer, and the sacred tree is dead.

"He said to them, 'But now if you have a purse, take it, and also a bag; and if you don't have a sword, sell your cloak and buy one.'" — **Jesus Christ** (Luke 22:36)

"The time to repair the roof is when the sun is shining." -- **John F. Kennedy**

The Important Things are Always Simple,
The Simple Things are Always Hard,
The Easy Way is Always Mined.
-From "Murphy's Laws of Combat

"If the personal freedoms guaranteed by the Constitution inhibit the government's ability to govern the people, we should look to limit those guarantees" - **William Jefferson Clinton 8-12-1993**

Black Elk - I did not know then how much was ended. When I look back now from this high hill of my old age, I can still see the butchered women and children lying heaped and scattered all along the crooked gulch as plain as when I saw them with eyes still young. And I can see that something else died there in the bloody mud, and was buried in the blizzard. A people's dream died there. It was a beautiful dream....the nation's hoop is broken and scattered. There is no center any longer, and the sacred tree is dead.

Even the mightiest Oak, was once a small nut that stood its ground

Power Corrupts, Absolute Power Corrupts Absolutely

"Any fool can criticize, condemn and complain, and most fools do." -- **Benjamin Franklin**

"Beware the leader who bangs the drums of war in order to whip the citizenry into a patriotic fervor, for patriotism is indeed a double-edged sword. It both emboldens the blood, just as it narrows the mind. And when the drums of war have reached a fever pitch and the blood boils with hate and the mind has closed, the leader will have no need in seizing the rights of the citizenry. Rather, the citizenry, infused with fear and blinded by patriotism, will offer up all of their rights unto the leader and gladly so.
-How do I know? For this is what I have done. And I am Caesar." -- **Julius Caesar**

"One who asks a question is a fool for five minutes; one who does not ask a question remains a fool forever." -- **Chinese Proverb**

"A man lives by believing something, not by debating and arguing about many things." -- **Thomas Carlyle**

"Wisdom outweighs any wealth." -- **Sophocles**

"Some are born great, some achieve greatness, and some have greatness thrust upon them."
-- **William Shakespeare**

"The peace and stability of a nation depend upon the proper relationships established in the home."
-- **Jade Snow Wong**

"No man can tame a tiger into a kitten by stroking it." -- **Franklin Delano Roosevelt**

"Next the statesmen will invent cheap lies, putting the blame upon the nation that is attacked, and every man will be glad of those conscience-soothing falsities, and will diligently study them, and refuse to examine any refutations of them; and thus he will by and by convince himself that the war is just, and will thank God for the better sleep he enjoys after this process of grotesque self-deception."
Mark Twain, The Mysterious Stranger, 1916, Ch.9

"It is not the man who has little, but the man who craves more, that is poor." -- **Seneca**

"The strongest word in the***English language"***

The word "shall" is an imperative with no alternative, and is the strongest word in the English language, permitting no other course of action than the one indicated. Period.

Whether you choose to ever own a gun of any kind -or not- is personal decision that you should have the freedom to make.

Why?

Because such a freedom is basic to the American way of life.

The Founding Fathers of this great nation knew that a free people -people who were allowed to make the decisions that most directly affect their own lives- would also protect the nation that provides them with such freedom. Those Founding Fathers were also possessed of an all-encompassing faith in Almighty God, giving Him the praise for aiding them in their every accomplishment, and committing everything - including their very lives- into His hands because they trusted Him to fulfill His Word and prosper this new nation of heretofore unheard of personal, individual freedom.

They could not possibly have foreseen this day -225 years later- when God-less heathen would rule over the people whose freedom they had purchased with their own blood, as it soaked into the earth at Concord and Bunker Hill -and was swallowed up and diluted by the cold waters of the Atlantic Ocean. Because they believed in the people of those generations who would follow them, they wrote simple laws to constitute a solid government; they saw no need to complicate simplicity with an extravagant overabundance of words.

The Second Amendment -about which billions of words have been written since 1970- contains only 27 words that extends the right of self-defense to the individual, sovereign States, and to every citizen of those States:

"A well-regulated militia being necessary to the security of a free State, the right of the people to keep and bear arms shall not be infringed"

Amendment II of the United States Constitution

Those Socialists and Marxists in our Federal government today shudder at the thought of you understanding the import of those 27 words, and they have fought valiantly to suppress any truthful interpretation of the Second Amendment.

What is the truth? Again, simplicity.

A "*well-regulated militia*" means an orderly group of men and women -citizens all- who have supervision under the authority of someone with some knowledge of military order and discipline; obviously, a "well-regulated militia" is not a ragtag mob of unruly dissidents.

The phrase "*..being necessary to the security of a free State*" clearly sets out the possibility that the central government might at some time try to conquer the sovereign States with military force -which is precisely what took place in 1861.

Some misinformed people today think that "militia" translates to "National Guard", but this is a lie put forth by the Federal government: the "National Guard" can be nationalized by the President on a moment's notice, leaving a State with no military protection whatsoever.

And here is what Washington does not want you to know: a "*militia*" is under the control of the Governor of the sovereign State, and any attempt by the Federal President at taking control of the "militia" is an act of war against that State!

"...the right of the people to keep and bear arms shall not be infringed."

Members of a formal militia have historically been required to provide their own weapons, going back to the time prior to the American Revolution. And, if the militias are ever again required to defend their home States, they will again be required to first provide their own weaponry: it is, therefore, clearly seen that every American citizen MUST have the right to own and keep guns, whether they do so or not; there will always be some -pacifists- who will force others to defend them at the risk of their own lives.

The word "*shall*" is the key to the ending phrase: it is an imperative with no alternative, and is the strongest word in the English language, permitting no other course of action than the one indicated.

Period.

It is no coincidence that the same people who want the Confederate flags hidden away are the same ones who want all American citizens to be disarmed: an unarmed citizenry is helpless to defend itself against any aggressor, especially its own ruling government. This is why those who wish to conquer a nation must first make certain that its people cannot defend themselves against a detachment of armed soldiers at their door.

Before the Cold War, the Russians bullied and threatened, vowing to blow America to smithereens with atomic weapons -a threat that was as empty as the heads of those who believed they would do it.

(a) to bomb America with nuclear weapons would have destroyed the United States, true -but the land would have been useless to Russia or anyone else for at least 100 years because of the residual radiation and

(b) not even the huge Russian army could have conquered America where almost every citizen owned a gun; any invading army would be cut to pieces in short order, by being fired upon from virtually every house on every street.

So, another means had to be found.

You can write it in your diary: when American citizens no longer have the right to freely buy, sell, own and trade guns, American citizens shall be the prisoners of a dictator within 20 years. Now, look at the people who want to take away all of your freedoms: you have been warned, and you can no longer plead ignorance.

Personally, I do not fear people with guns: I fear people without them, for the simple reason that an unarmed person will likely be unable to help me -should I need help, in a desperate situation!

Author unknown

A mixed victory for gun rights

Sheldon Richman (Published Dec 28 2001)

Fans of the Second Amendment are rejoicing because a federal appellate court has affirmed that the right to keep and bear arms belongs to individuals, not collectives. Anyone who can read plain English already knew that. But now we have a U.S. appellate court saying so. That can't hurt.

The ruling of a three-judge panel from the Fifth Circuit Court of Appeals grew out of the Texas case of Timothy Joe Emerson. Dr. Emerson was going through a divorce and was subject to a temporary restraining order. Federal law forbids anyone subject to a restraining order to have a firearm. He was charged with violating that federal law.

In 1998 Emerson challenged the law, and Federal District Court Judge Sam R. Cummings declared it unconstitutional on grounds that Second Amendment rights are too important to be abrogated by so casual a means as a "boilerplate" restraining order in a divorce action. He also demonstrated that the amendment applies to individuals, not state national guards. This set the stage for the appellate ruling.

Two of the three appellate judges endorsed Judge Cummings' ruling that gun rights are individual rights. They determined that the 1939 U.S. Supreme Court case *U.S. vs. Miller*, which the gun controllers depend on, fails to support the collective-rights position. *Miller* in no way hinged on whether the defendants were members of the National Guard. In fact, the Supreme Court noted that at the time of the framing of the Constitution the militia was considered to consist of "all males physically capable of acting in concert for the common defense."

Thus the appellate judges authoritatively pulled away a key pillar of the gun controllers' case. The Supreme Court has never held that the right to keep and bear arms is something other than an individual right.

Further, the appellate court disposed of the argument that the amendment's preamble, "A well-regulated militia being necessary to the security of a free state," implies a collective right. They pointed out that the preamble is fully consistent with the individual-rights interpretation.

The Fifth Circuit appellate judges followed up this logical argument by delving into the historical record and concluded: *"We find that the history of the Second Amendment reinforces the plain meaning of its text, namely that it protects individual Americans in their right to keep and bear arms whether or not they are a member of a select militia or performing active military service or training."*

Gun Control Success

-In 1911, Turkey established gun control. From 1915 to 1917, *1.5 million* Armenians, unable to defend themselves, were rounded up and exterminated.

- In 1928, Germany established gun control. From 1939 to 1945, *13 million* Jews, gypsies, homosexuals, the mentally ill, and others, who were unable to defend themselves, were rounded up and exterminated

-In 1929, the Soviet Union established gun control. From 1929 to 1953, approximately *20 million* dissidents, unable to defend themselves, were rounded up and exterminated. (where are all the millions \$\$\$ in compensation for these folks holocausted in Communist Gulags???)

-In 1935, China established gun control. From 1948 to 1952, *20 million* political dissidents were unable to defend themselves and were rounded up and exterminated.

-In 1956, Cambodia established gun control. From 1975 to 1977, *one million* "educated" people, unable to defend themselves, were rounded up and exterminated

- In 1964, Guatemala established gun control. From 1964 to 1981, *100,000* Mayan Indians, unable to defend themselves, were rounded up and exterminated..

-In 1970, Uganda established gun control. From 1971 to 1979, *300,000 Christians*, unable to defend themselves, were rounded up and exterminated.

