

Monday, August 27, 2007

Tell your friends, you found it at:



Serving HAM Radio since 1959, On the Web Since 1995

**Order Toll Free Monday through Friday, 9 am to 4 pm, 1 800 726 2919 or 1 866 300 1969, Saturday 9 AM to 2 PM ALL Times, Eastern**  
**NO MINIMUM ORDERS, Same Day Shipping, except Sunday and Holidays** BUXCOMM Corporation 115 LUENBURG DRIVE EVINGTON, VIRGINIA 24550

**Please DO NOT call Order Lines with technical questions. Our order lines are managed by sales personnel, and cannot transfer to tech support.**

**BUXCOMM Tech Support is by expert ARO's, Technicians and Engineers. \*Tech Support; Email; [support@buxcomm.com](mailto:support@buxcomm.com)**

We accept:



**NOTICE: We ship WINDOM and G5RV antennas worldwide, However; Due to excessive damage, we cannot ship HF Mobile or VHF Base antennas outside the continental USA !**

# THE HAM RADIO OPERATOR'S ANTENNA HANDBOOK

by Buck Rogers ( K4ABT, for over 60 years)

For TNC to Radio Interface Cable Diagrams, CLICK HERE ! For PSK31 & SSTV Interface Diagrams, CLICK HERE !

**[A Method for hanging a BALUN without adding stress to BALUN binding posts.](#)**

**[Of all HF antennas, the multi-band WINDOM is my favorite.](#)**

**[An improved 6 Meter "High-Performance" Base-Station Dipole.](#)**

**[HF Antenna Cutting Chart](#)**

**[VHF & UHF Antenna Cutting Chart](#)**

**[Determine correct spacing between antennas to achive proper isolation.](#)**

**[A two meter dipole](#)**

**[A TV twin-lead two meter J-Pole; It's very portable and EZ to build !](#)**

**[Detailed drawing of a two meter "J" Pole antenna.](#)**

**[Detailed drawing of a six meter "J" Pole antenna.](#)**

**[Design your own "J" Pole antenna.](#)**

**[Design your own QUAD antenna.](#)**

**[A 4 element, six meter QUAD design using \*Design-A-Quad\*.](#)**

**[Antennas and Antenna RF Meters](#)**

---

BUT FIRST.... let's review some antenna "basics" in pictorial form.

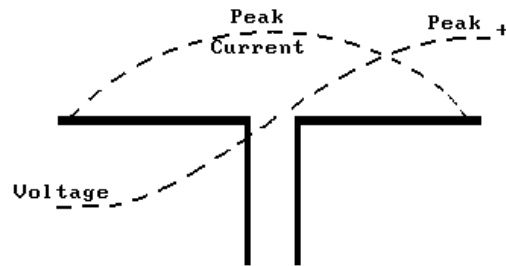

The basic dipole consists of two charges or elements which receive signals of opposite polarity.

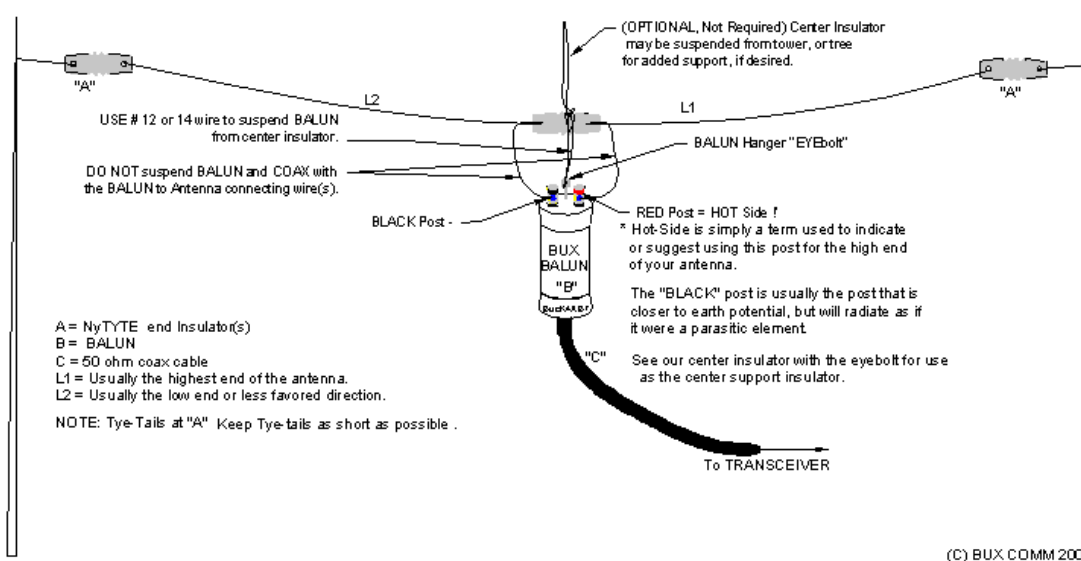

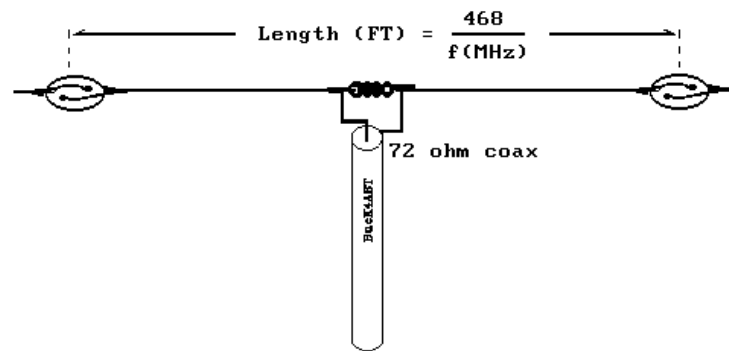

**A dipole is a half-wave antenna fed at the center.  
The impedance at the center is near 72 ohms.**

When using a Dipole made similar to the above antenna, it is highly recommended that a 1:1 BALUN be used at the antenna feed point (center insulator).

---



Read why:  
BUX BALUN  
is

## The # 1 selling BALUN

At BUX COMM, \*We don't cut corners!

The elements used in the development of our BUX BALUNS are manufactured from top quality components, beginning with the Silver Plate SO239 connectors and center insulator, made of teflon™(E.I Dupont).

The wire we use to wind the ferrite donuts is heavy-duty, silver flashed wire, with teflon™ insulation that will handle RF voltages above 15000 volts, and temperatures to 1000 degrees. The binding posts are heavy-duty, tempered brass, with end holes and side-thru holes to accommodate either type loop-thru connection. A double-shoulder brass capture nut is used to add a secure bite and improve antenna wire electrical connections.

BUX BALUNS are analyzed and tested in our lab, using a *General Radio Impedance Bridge (GR1145)* and Rohde & Schwarz, Vector Signal Generator and RF Spectrum Analyzer, (SAM300) from 9 kHz -3 GHz to a WALFEUR 3000 watt, step range Pyronol-Dummy Load (SRDL3K).

With our BUX UN UN (ONION), the coax is Belden™ RG8X and the PL259 connectors are Amphenol™ with Silver flashed SO239, and Gold center pins. Center Insulator is Teflon™ (EI DuPont)

**BUX UNION \$19.95**

model **BUXUNUN**



- o 50 ohm, SO-239 unbalanced input
- o UNBalanced output
- o Two feet, RG8X to PL259
- o 1.5 to 54 MHz (160 Mtrs to 6 Mtrs)
- o Toroid (CURRENT) design
- o Heavy Duty, Lightweight
- o Sealed against moisture

**\$19.95 ADD TO CART**





**MM11**  
**ADD TO CART**

### CARDINAL 1:1 BALUN

BUX COMM MasterMatch 11 Baluns are ideal for dipoles, Slopers, InvertedVeets and center feedpoint, RV antennas.feedpoint, RV antennas. "CURRENT"

\$19.95

 <p style="text-align: center;"><b>MM41</b> <b><u>ADD TO CART</u></b></p>	<p style="text-align: center;"><b>BLACK HAWK 4:1 BALUN</b></p> <p>BUX COMM MasterMatch 41 Baluns are ideal for windoms and antennas fed with 250 to 500 ohms transmission lines <b>"CURRENT"</b></p>	<p style="text-align: center;">\$19.95</p>
 <p style="text-align: center;"><b>SDAB</b> <b><u>ADD TO CART</u></b></p>	<p style="text-align: center;"><b>Screw Driver Antenna Balun model SDAB</b></p> <p>Works great with SCREWDRIVER and EndFed Mobile antennas</p>	<p style="text-align: center;">\$19.95</p>



## MOBILE KING, Antenna BUX MOBALUN

*For bottom fed, and Screw-Driver antennas.*

**1.8 MHz to 54 MHz *Master Match***

50 ohm, SO239 unbalanced input. Unbalanced output PL259,  
1.8 to 54 MHz, silver plated screws, and silver SO239 input connectors.

- o **FREE** 3ft RG8X coax jumper with PL259's.
- o 1.8 to 54 MHz
- o Ferrite (current) Broadband Toroid design
- o Heavy Duty, Lightweight construction
- o SO-239 UNbalanced input.
- o SO-239 UNbalanced output,
- o Sealed against moisture

Order BUXMOBALUN \$19.95



## BUX VBALUN De-Coupling transformer

### Primary use and application:

**Feed point isolation and matching for J-Poles and VHF/UHF BEAMS.**

This decoupling transformer prevents RF currents from traveling down the outer shield of the coax. The input connector is an SO239 (female) and the output connector is a PL259 (male).

**BUX "VBALUN"** De-Coupling transformer, has SO-239 (female) input connector. Output connector is 2 feet RG8X cable with Amphenol PL-259 (male). BUX VBALUN is an UNbalanced to UNbalance decoupling transformer designed to be used by the Apartment dweller or the RV ops when feeding J-Poles and similar VHF/UHF antennas.

**\$19.95 VBALUN**

[Add to cart](#)

Teflon <sup>®</sup>™ E I DuPont corp.  
Amphenol <sup>®</sup>™ TYCO Corp.

## AE41 4:1 High Performance, Heavy Duty, 2.5 KW Balun

\*CW/SSB duty-cycles only. *SSB/CW Power @ 3.5 MHz\* >2.5 kW if SWR is less than 3 1*

\*Not rated for AM, RTTY or other high/long duty-cycle digital modes.



- ✚ Double-co-efficient coupled design.
- ✚ Exceptional High output.
- ✚ Large toroid ferrite cores.
- ✚ High winding reactance with only a L-C compensatio.
- ✚ Teflon insulated, large gauge, high temperature, wire.
- ✚ Compensation for wide bandwidth
- ✚ Rated above the legal power limit.
- ✚ Heavy-Duty, 1 inch, Stainless-steel eyebolts.
- ✚ Input Connector SO-239



- ⚡ Output Connector Hard-Drawn, tempered Brass Binding Posts.
- ⚡ Bandwidth 160 - 10 m.
- ⚡ Power Loss, dB less than 1 dB.

**ADD TO CART**



**ADD TO CART**

**Similar to above AE41, except:  
1:1 (One to One) BALUN AE11**

Our BUXCOMM 'American Eagle' is rated for 2500 watt SSB service, 1 to 1 CURRENT type, High Performance, Heavy Duty, BALUN. Built for power, strength, and durability, and most of all, maximum transfer of RF energy to your antenna. At BUXCOMM, we don't cut corners. Hardened Brass terminals, large, low permeability ferrite cores to prevent core saturation at high power peaks. Internal connections are silver-bearing soldered, coaxial connectors are silver plated, with teflon insulators, and gold flashed center pin. 1.8 MHz to well into the VHF region.

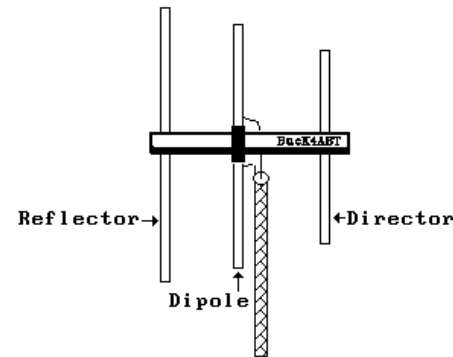

Adding a reflector and a parasitic element (director) to the dipole greatly improves its gain and directivity. Thus, the dipole becomes a "YAGI" antenna.

**[Good photos of VHF & UHF YAGI](#)**

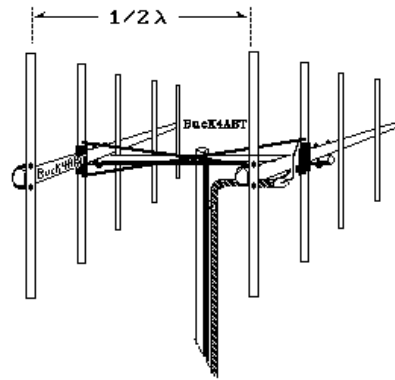

Two yagis, stacked  $1/2$  wavelength apart  
will render another 3 dB of gain.

---

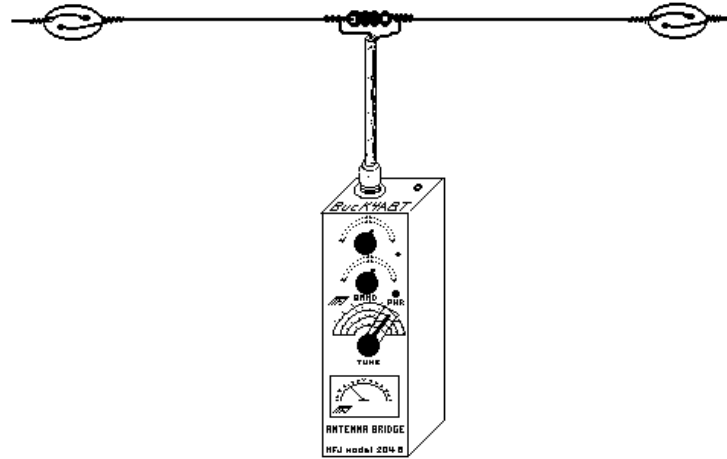

By using the "ANTENNA BRIDGE" the guess-work is  
removed and the correct cable length and impedance  
is sooner realized.

---

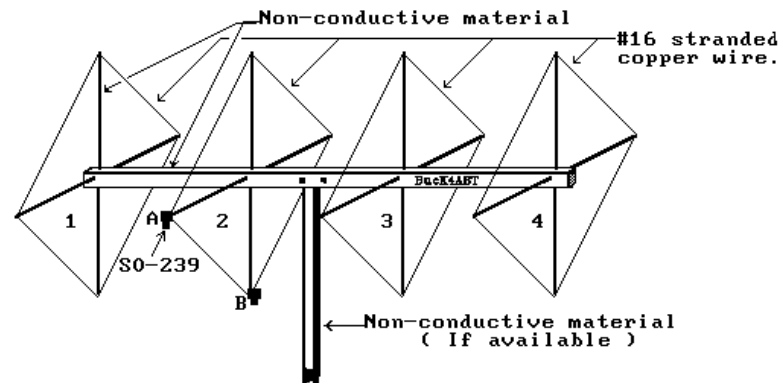

**BASIC CONSTRUCTION OF A QUBICAL QUAD ANTENNA**  
 The "QUAD", feed point "A" for vertical polarization. Feed point "B" for horizontal polarization. Element (1) is reflector, (2) is driven element, 3 & 4 are directors.

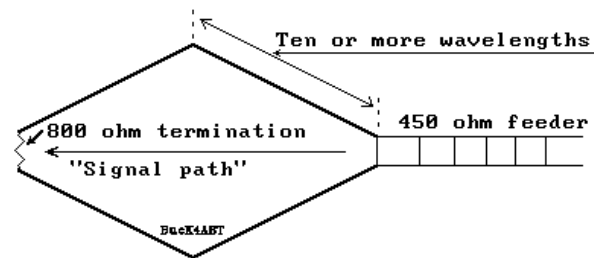

The "ROMBIC" is a highly directional and very high gain antenna. It also requires a large parcel of real-estate.

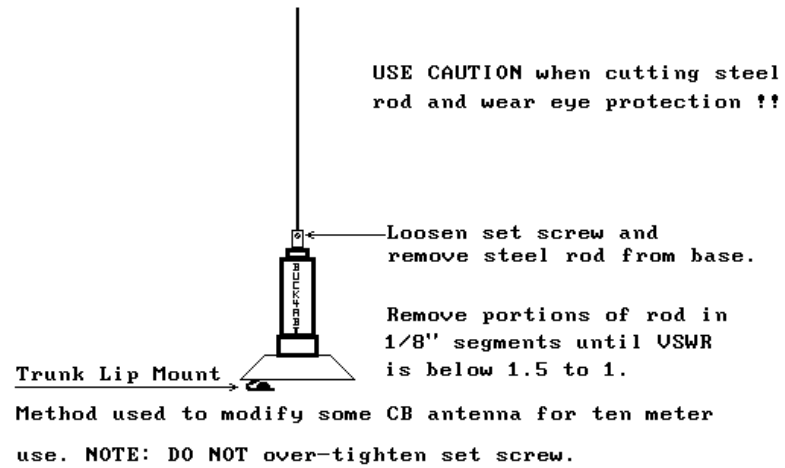

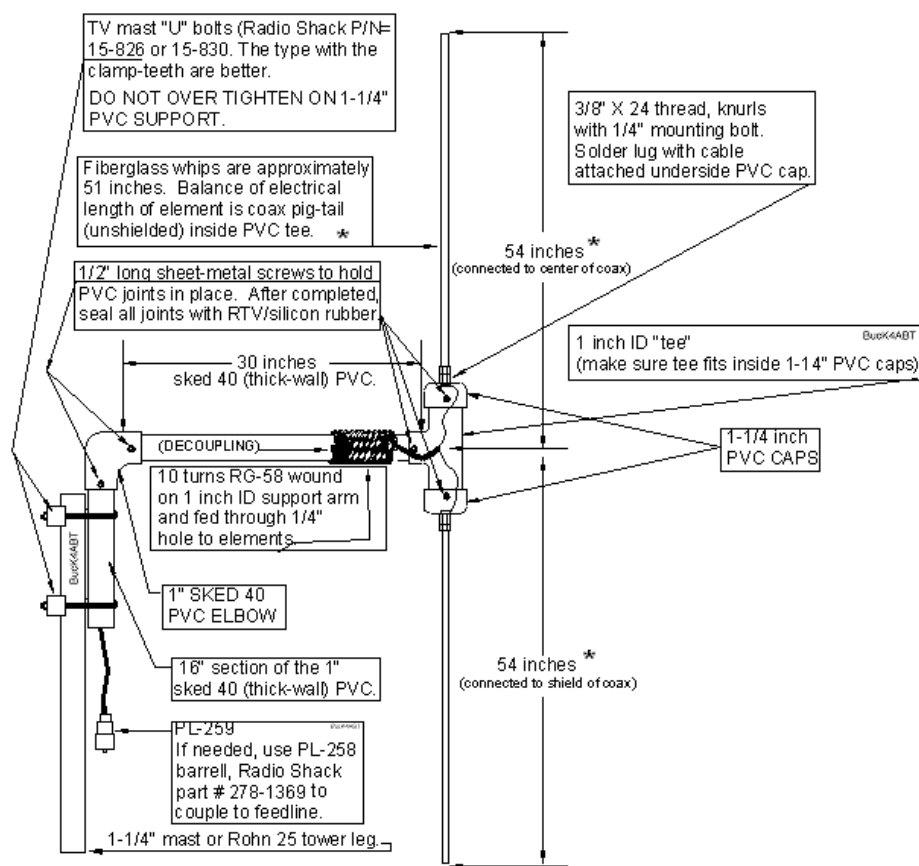

An improved "High-Performance" 6 meter Base-Station Dipole  
[Antennas & Accessories](#)



[CLICK ON the small graphic to view full size.](#)  
 Half-Wave HF Antenna Cutting Chart.

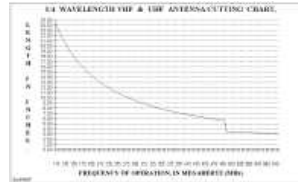

[CLICK ON the small graphic to view full size.](#)  
VHF/UHF Cutting Chart

---

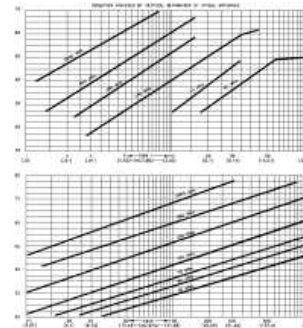

[CLICK ON the small graphic to view full size.](#)  
Antenna Isolation / Spacing Charts

---

**[HAM Radio and Commercial 2-way radio antennas](#)**

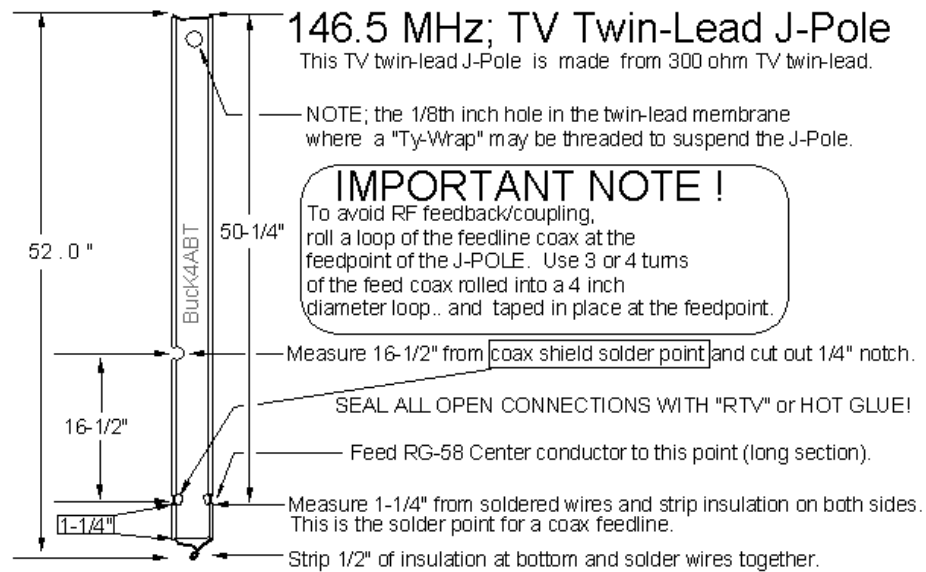

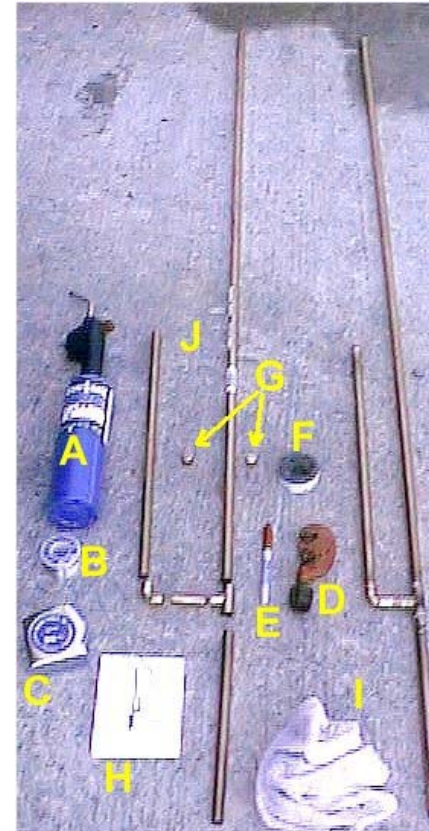
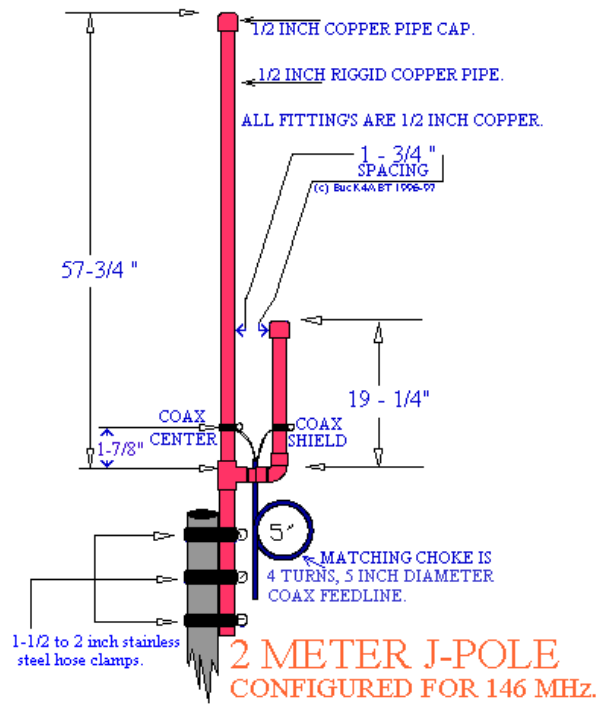

A=Benz-O-Matic propane torch; B=Lead-Free solder; C=Tape measure; D=Tubing cutter; E=Sharpie marking pen; F=Solder Paste; G=1/2 inch copper caps; H=Hardcopy of the above drawing; I=Wet Towel; J=PreCut, ready to assemble parts of the 2 meter J-Pole.

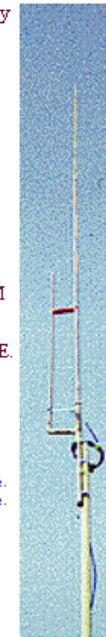
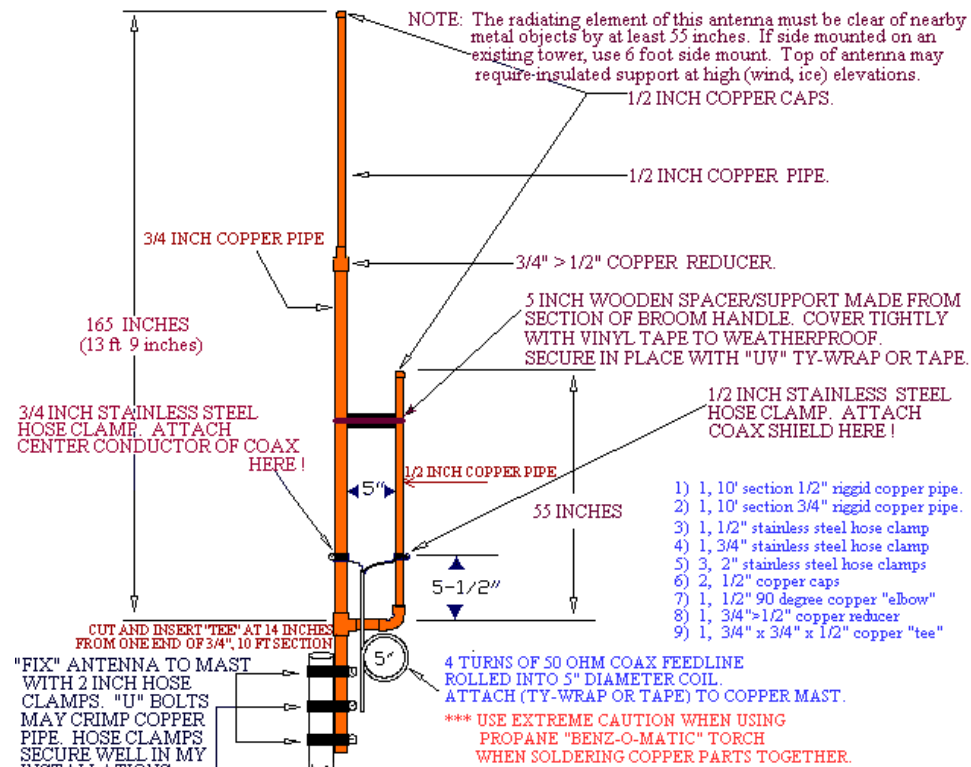

by Buck Rogers K4ABT  
 6 METER "J" POLE ANTENNA; DIMENSIONS ARE FOR 51 MHz

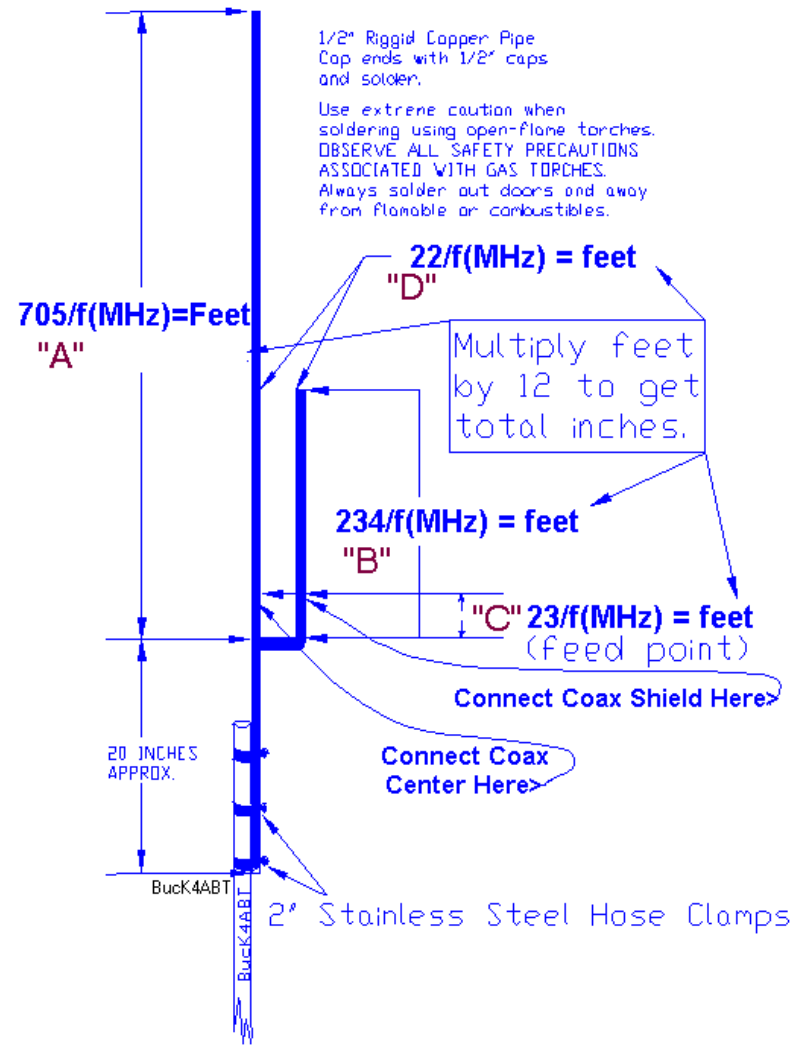

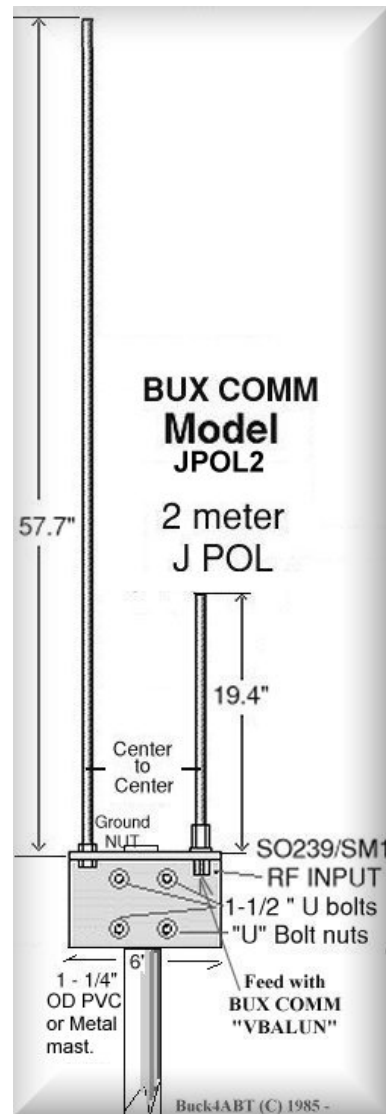

BUX COMM, 142 to 150 MHz; Fiberglass J pol  
 For low terrestrial noise, use fiberglass elements. For optimum performance and gain,  
 feed with BUX COMM "VBALUN."  
 Courtesy HRC Antenna Newsletter (c)

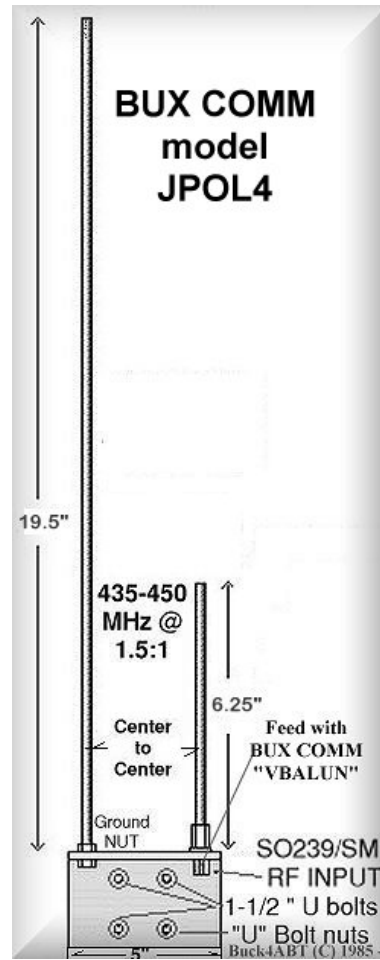

BUX COMM, 435 to 450 MHz; Fiberglass J pol  
 For low terrestrial noise, use fiberglass elements. For optimum performance and gain,  
 feed with BUX COMM "VBALUN."

Courtesy HRC Antenna Newsletter (c)

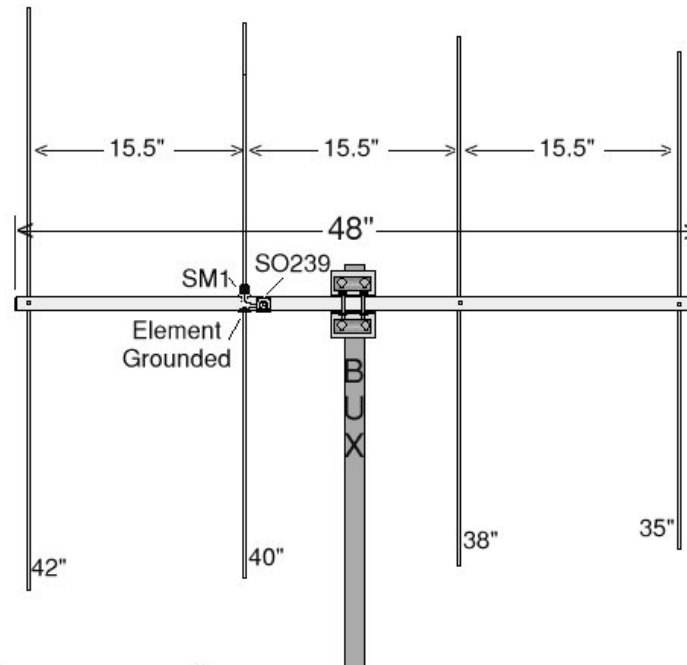

Four element, two meter beam, elements can be tubular aluminum, solid aluminum, or for low terrestrial noise, use fiberglass elements. This beam may be installed vertical, or horizontal. For optimum performance and gain, feed with BUX COMM "VBALUN."

Courtesy HRC Antenna Newsletter (c)

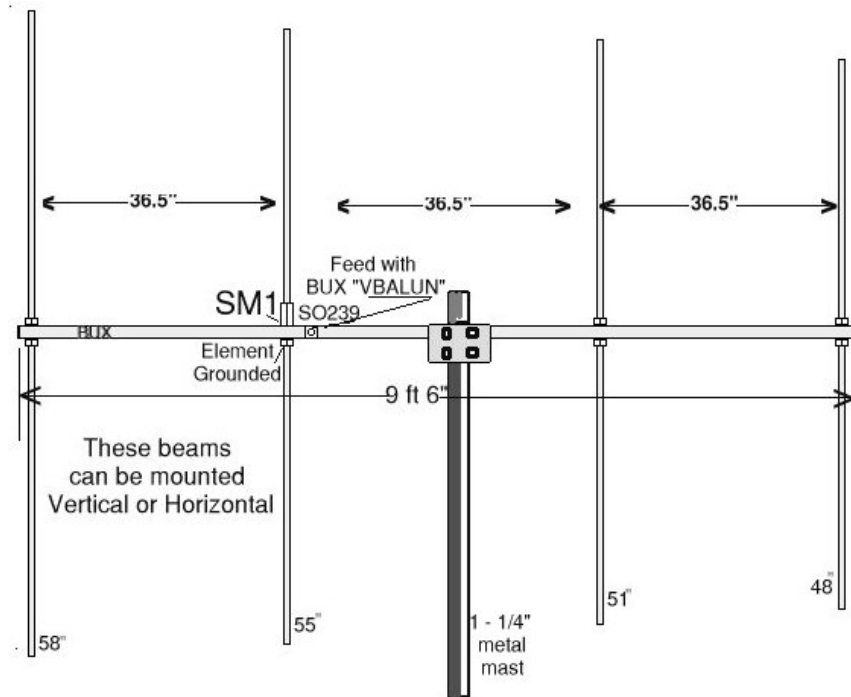

Four element, six meter beam, elements can be tubular aluminum, solid aluminum, or for less terrestrial noise, use fiberglass elements. This beam may be installed vertical, or horizontal.  
 Courtesy HRC Antenna Newsletter (c)

## Design-A-Quad Antenna

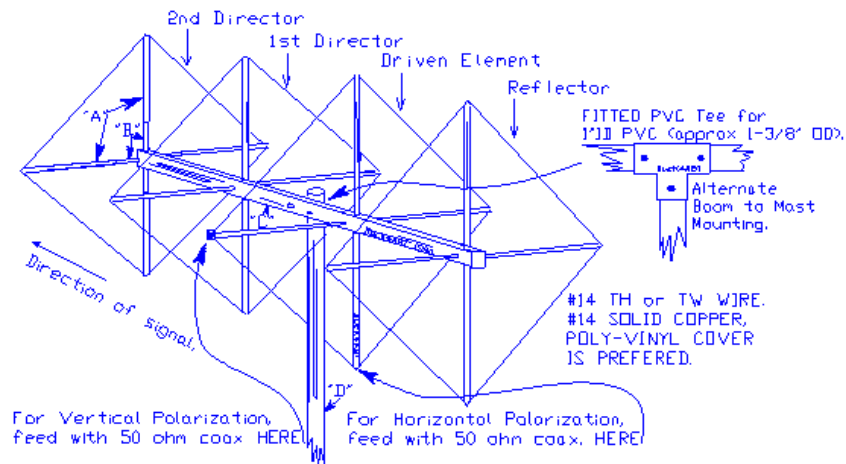

For Vertical Polarization, feed with 50 ohm coax HERE.

For Horizontal Polarization, feed with 50 ohm coax. HERE.

\*A\* = 1/2" ID hot/cold PVC. PVC should fit securely over 1/2" OD wooden dowel \*B\*.

\*B\* = 1/2" OD wooden dowel 2 ft long through 1" ID boom. Dowel should extend approximately 9-1/2" out from each side of 1" ID boom. Fit 1/2" PVC (\*A\*) over dowel. Make sure spreader is long enough to support each wire element length as determined by the calculations below. Once PVC is in place over the wooden dowels, drill with small bit and use short wire or picture hanger nail to secure on the dowel. Hot glue may be used as an additional keeper over the wire or nail head.

\*C\* = Boom may be made from square fiberglass or from round PVC 1" ID. Boom is drilled with 1/2" bit at points where wooden dowels are to be inserted.

NOTE: Make sure the vertical and horizontal dowel holes are drilled offset so the dowels will by-pass each other inside the boom. Drill dowels with 1/16" (or smaller) bit each side of boom and secure with small nail or wire to hold (centered) in place. BOOM is thick wall 'Sked 40' 1" ID PVC.

\*D\* = 1" ID (sked 40/Thick wall)PVC 48" long. Use "fitted" wooden dowel inside to make it more rigid and provide "body" to area where "U" bolts may be attached (rotor head end to boom). See alternate boom mounting.

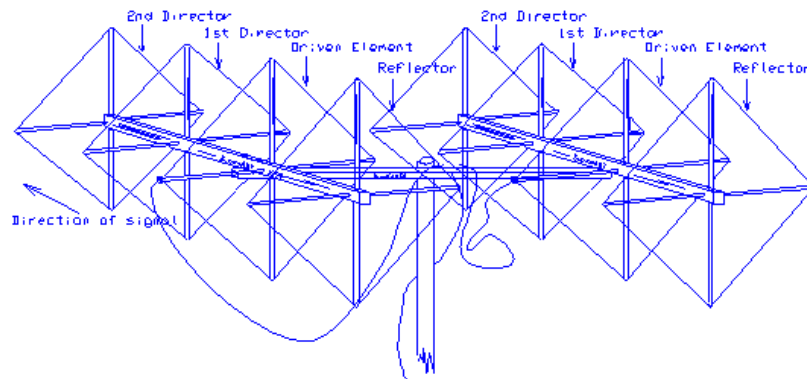

Horizontal "stacking" of quads will improve the signal strength by at least 3 DB. The QUAD's inherent immunity to terrestrial noise, makes it the ideal antenna (beam) for Packet Radio use.

**Measurements and dimensions for the QUAD antenna are found using the QUAD design calculator below.**

**Calculate the total wire length for each element of a quad antenna.**

**REFLECTOR = 1030 / F (MHz)**

**DRIVEN = 1005 / F (MHz)**

**DIRECTOR 1 = 975 / F (MHz)**

**DIRECTOR 2 = 960 / F (MHz)**

**ELEMENT SPACING** between:

1) Reflector & Driven Element = 730 / F (MHz)

2) Driven Element & 1st Director = 600 / F (MHz)

3) 1st Director & 2nd Director = 600 / F (MHz)

**Enter the formula for the antenna calculation**

Divided by  Freq MHz  
Calculate Element Wire Length or Element Spacing

Total wire-length in feet is  **FEET.**

Total wire-length in inches is  **INCHES.**

One of four sides in FEET =  <- Use **ONLY** this number for "element spacing" when entering the **element spacing** numbers (constants; 730 or 600) above!

**Total all spacing measurements (in inches) then add 2 inches for each end.**

**THE QUAD SHOWN BELOW IS AN EXAMPLE OF A QUAD DESIGN USING *DESIGN-A-QUAD* ABOVE**

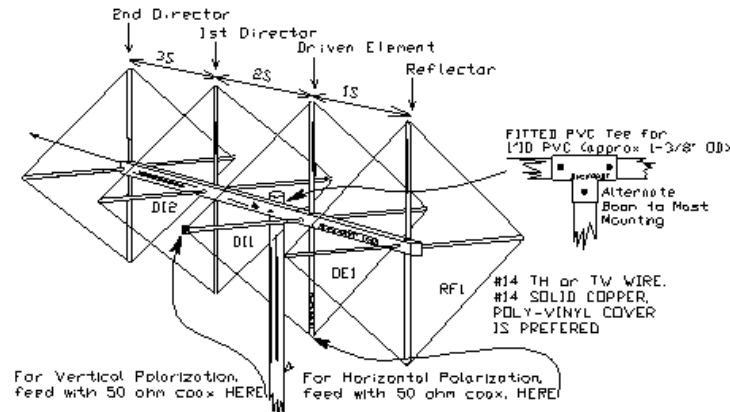

AN EXAMPLE OF A 4 ELEMENT, SIX METER QUAD  
(C) Buck4ABT 1989-2006

TOTAL ELEMENT WIRE LENGTHS

RF1 = 241-3/4 INCHES  
DE1 = 236-0"  
DI1 = 229-0"  
DI2 = 225-0"

LENGTH OF ONE SIDE

60-1/2 INCHES  
59-0"  
57-1/4"  
56-1/4"

ELEMENT SPACING

1S RF1 to DE1 = 43 INCHES  
2S DE1 to DI1 = 34 INCHES  
3S DI1 to DI2 = 34 INCHES  
ADD 2 INCHES AT EACH END  
TOTAL BOOM LENGTH = 115 INCHES

When stacking two of these quads, use 44 inch lengths of 75 OHM cable from Coax "TEE" connector to each Quad. Coax from transmitter to "Tee" is 50 ohm coax. As viewed above, for vertical polarization, feed both quads as shown (left side). For Horizontal polarization, feed both quads at bottom of the driven element (as indicated).  
(C) Buck4ABT 1989-2006

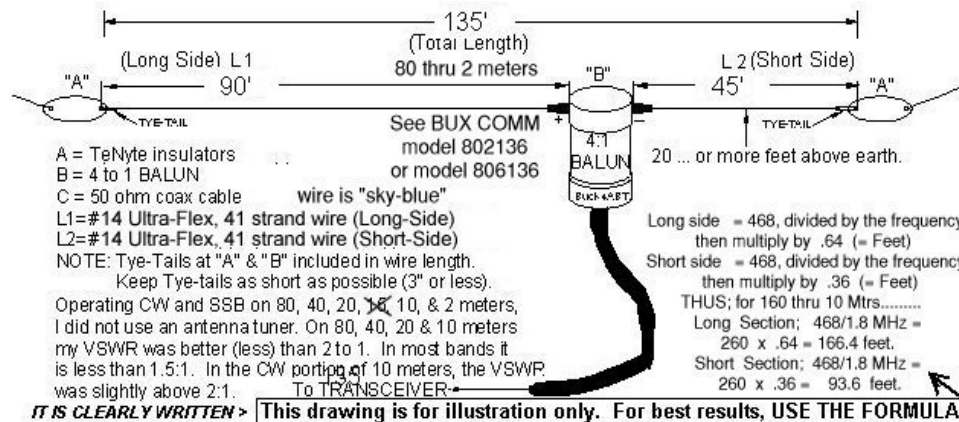

If you prefer; Order [↑ BUX COMM WINDOM](#) [↑ "without coax" Model 802136](#)

Above [Windom with Fifty ft. \(50'\) RG8X coax and connectors](#), \$ 79.95 802136W50

Above Window with One Hundred ft. (100') RG8X coax and connectors, \$ 95.95 802136W100

The Window can be installed as a Droop-End (see *figure D* below) or as a sloper, but in no case, should the angle be greater than 90 degrees against itself. To use an angle that folds against the pattern of the opposite end, or the feed line of the Window, could change the impedance of the feed-point, change the multi-band features, and most important, destroy the radiation characteristics of the antenna.

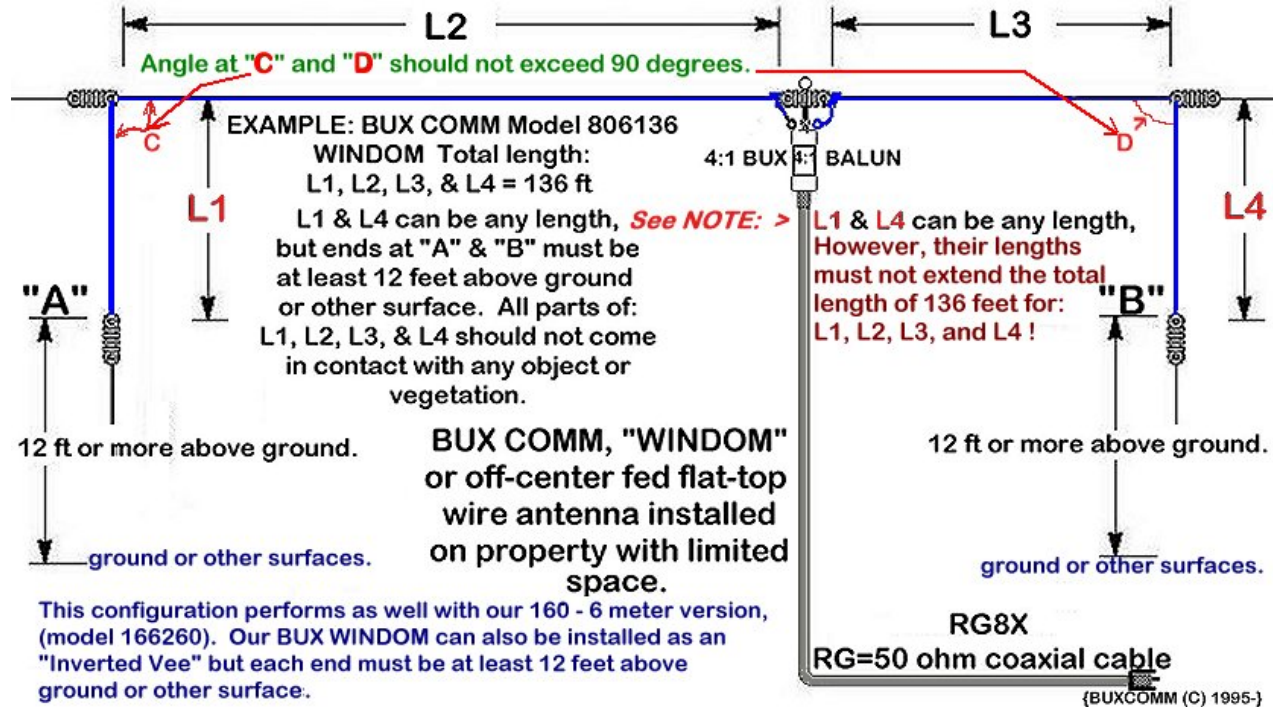

Figure D

In other words, install the Window as you would any other dipole, while using a common sense approach. The fact that we are feeding this Window using coax, and a single balun, gives us the ability to construct it as a drooped-end antennas or at a "real estate saving (angle)" without destroying the features and performance of the Window.



WE Accept →

**NOTICE:** We ship WINDOM and G5RV (wire type) antennas worldwide, However; Due to excessive damage, we **DO NOT** ship Mobile HF or Base VHF antennas outside the continental USA !

**For those who want lightning protection, here is one of many, lightning protection device.**

**An HF Dipole Antenna specially designed with the Apartment Dweller, RV, & Field-day operator in mind.**

Don't be fooled by those over-priced knock-offs that use a piece of drilled aluminum that breaks in a cold wind. This is the original, Fixed station, RV, apartment dweller, and portable dipole from BUX Communications. It is designed for rapid deployment and effective HF communications where space is limited. The mounting bracket and hardware are made of high-quality, hard-drawn, aircraft aluminum, to withstand the elements and maintain a strong posture in adverse wind and weather conditions.

**On a budget, Mobile in an RV, or live in a space-restricted environment?.. Here's the the solution:** Here's an HF horizontal (or vertical) polarized antenna that will meet those beams "head-on!" When installed on a rotor, this combo makes a great bi-directional fixed-station antenna. Shown here with BUX UNUN (ONION) as the decoupling balun (unun) to prevent reradiating of the coax shield and better match at the antenna feed point.



BCC Photo ©

When the stations with the gain and power in their antennas are transmitting in the horizontal plane, then you should be meeting them in the same plane. Horizontal signals tend to follow the earth's contour, and are easier to capture using a horizontally polarized antenna. See the BUX UNUN elsewhere on this page.

By combining a pair (two) of the single band HF Mobile (loaded) **tunable-tip** antennas, you can have an ideal, single element, (bi-directional) horizontal dipole.

← At left; is a photo of the BUX CommCo dipole configuration using a pair of our model **BHF20M** mobile antennas, and our model **DABRKT** "Double Antenna BRacKeT." The **DABRKT** will fit up to one and a quarter inch (1-1/4") diameter mast.

The supporting mast is attached to the apex of our warehouse. Overall height of my antenna above ground is only 17 feet. When you see me on 20 meters (14,070,15 USB) running test on RASCAL interfaces, this is the antenna I am using.

←

By combining a pair (two) of the single band HF (VHF) whips at left, you can have an ideal, single element, horizontal dipole (beam). This type antenna opens the world of HF and VHF communications for the apartment dweller, RV HAM, field-day operating, and a variety of other uses and applications. Bracket alone is \$16.95

*tunable-tip antennas allow adjusting for minimum VSWR.*

[or see the DBLSPCL; details below](#) ↓

←

*When you see me in QSO on 20 meters, using PSK31, I am using this antenna mount with two of the BHF-20 M antennas at 17 ft. An FT-817 at 5 watts PEP, worked 50 + countries.*

When installed on a rotor, this combo makes a great bi-directional fixed-station antenna. *Turning radius, seventeen feet, (approx).*

HF Mobile (loaded), **tunable-tip** antennas

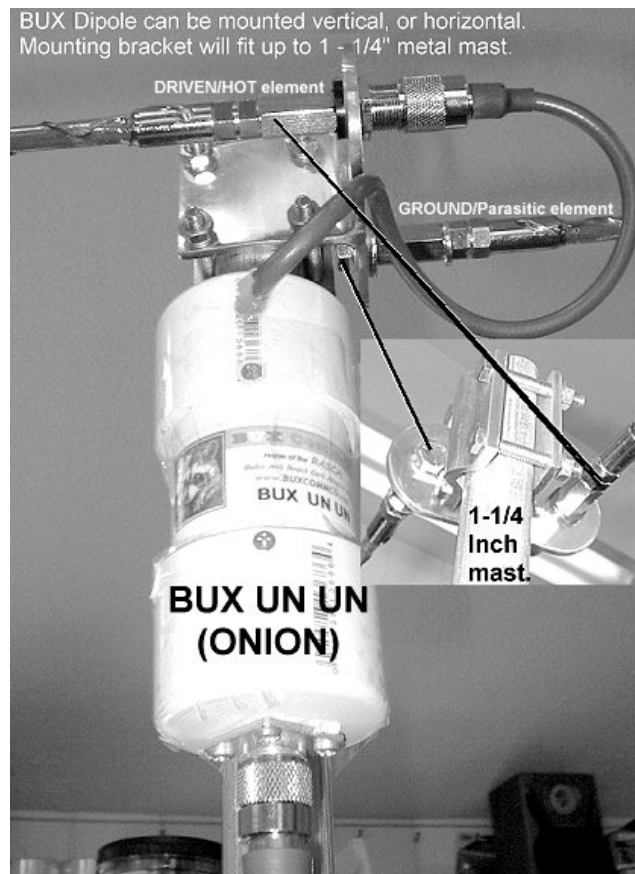

Photo above; **BUX COMM, "DBLCOMBO"**, see details below.  
BUX COMM © graphics 1998-2004 (c)

## INDEX to our web pages

**RASCAL GLX with both USB & Serial Interface**  
**RASCAL Kit & with FREE Radio Cable (64)**  
**MOBILE Antennas & Accessories**  
**WIRE Coax, Rotor, Power, Dacron Rope+**  
**METERS, Power, SWR, Panel, DMM, DVM**  
**AUDIO Connectors, Cables and Adapters,**  
**TOOLS & TEST EQUIPMENT**  
**SPEAKERS Headsets, & Accessories**

**RASCAL GLX Serial Cable only, w/FREE Cable**  
**PacketRadio to TNC Interface Cables**  
**BALUNS 1:1, 2:1, 4:1, 6:1, 9:1, 12:1, 16:1 & More**  
**TOROIDS BALUN Cores, & Noise Suppress**  
**POWER Cords, Fuses, Fuse Holders, Wire**  
**Audio and Power Transformers**  
**MICROPHONE Replacements & Headsets**  
**MAIL ORDER FORM**

**RASCAL to Radio Shack**  
**BASE Station Antennas**  
**RF Connectors, Cables**  
**Amateur Radio Test Equipment**  
**POWER CORDS, FUSES**  
**SWITCHES, RELAYS**  
**SOLID STATE, RELAYS**  
**MAIL ORDER FORM**

<b>LINEAR Installation Kits</b>	<b>ISO SoundCard to Transceiver Interface KIT</b>	<b>RASCAL Spare c</b>
<b>HAM Digital, PSK, &amp; Packet Books, Two CD set</b>	<b>MICELLANEOUS Items</b>	<b>RASCAL or TNC</b>
<b>Antenna Handbook Pt I</b>	<b>Antenna Handbook Pt . II J POLES FOREVER</b>	<b>Antenna Handbo</b>
<b>Antenna Handbook Pt IV</b>	<b>Antenna Handbook for the WINDOM Antenna</b>	<b>WF4W Tests the l</b>
<b>Accessory Jack, and Microphone Data</b>	<b>RASCAL&gt;Radio Interface Cable Diagrams</b>	<b>SOLVING HUM &amp;</b>
<b>Computer Connector Diagrams for HAMS</b>	<b>HAM microphone wiring index</b>	<b>Grid Square Map</b>
<b>A PSK31 Guide &amp; Handbook (Must Read)</b>	<b>Setup Tips for the New RASCAL GLX</b>	<b>Grounding &amp; Ligi</b>
<b>SOLAR power your Packet Nodes</b>	<b>HAM Radio Books on CD (set of 2)</b>	<b>Download our BL</b>
<b>Glossary of HAM Radio Digital Terms</b>	<b>Packet Radio Guide for the new HAM</b>	<b>PacketRadio Proj</b>
<b>PacketRadio Band Plan</b>	<b>Building Packet Networks Handbook</b>	<b>How to Build Pac</b>
<b>Parameters &amp; Setup TheNET X-1J4 Nodes</b>	<b>GE DELTA 1200 Baud MOD for Packet</b>	<b>GE DELTA 9600 t</b>
<b>GE PHOENIX 9600 b/s Packet Mod</b>	<b>BUXCOMM 9600 baud Packet Handbook</b>	<b>GE RANGR Mods</b>
<b>Motorola Mitrek Mod for 9600 b/s Packet</b>	<b>KANTRONICS KPC3 as an TheNET Node</b>	<b>EPROM Order Fo</b>
<b>PacketRadio Handbook by Buck4ABT</b>	<b>TheNET X1J4 NODE code and manuals</b>	<b>RASCAL Setup fc</b>
<b>RASCAL to IC 706 MK IIG for EchoLINK</b>	<b>Frequency Spectrum Allocations</b>	<b>CB Microphone V</b>
<b>LOTS of SoundCard Software for the RASCAL</b>	<b>HAM Radio Software &amp; FREEware</b>	<b>From a ZEPP to a</b>
<b>Alignment procedure for MFJ 1270 TNC</b>	<b>Display All Products &gt;takes a minute to load</b>	<b>Customers Comn</b>
<b>Shipping and Returns Policy</b>	<b>BUXCOMM Mail Order Form</b>	<b>HOME to BUXCO</b>
<b>HOME to PacketRadio.com</b>	<b>New HAM Radio site with lots of Info</b>	

Tell your friends, you found it at:



Serving HAM Radio since 1959, On the Web Since 1995

Order **Toll Free** Monday through Friday, 9 am to 4 pm, **1 800 726 2919** or **1 866 300 1969**, Saturday 9 AM to 2 PM ALL Times, Eastern  
**NO MINIMUM ORDERS, Same Day Shipping, except Sunday and Holidays.** BUXCOMM Corporation 115 LUENBURG DRIVE EVINGTON, VIRGINIA  
 24550

Please DO NOT call Order Lines with technical questions. Our order lines are managed by sales personnel, and cannot transfer to tech support.

BUXCOMM Tech Support is by expert ARO's, Technicians and Engineers. \*Tech Support; Email: [support@buxcomm.com](mailto:support@buxcomm.com)

We accept:



All text and graphics on these pages are ©<sup>®</sup>™ of G. E. Rogers Sr and BUX COMM Corp 1986 - 2007



[CLICK HERE](#) to download RASCAL GLX to REPEATER interface Instructions via EchoLink

### **Shipping/Handling & warranty Return policy**

*\* "RASCAL" is Registered trademark ©<sup>™</sup> of BUX Communications Corp (BUX CommCo <sup>™</sup>) \*(RASCAL<sup>™</sup>@ "Radio*

*We ship WorldWide; However: Due to a large number of losses, missing items, damage, and similar issues: WE DO NOT SHIP TO: Mexico, Indonesia, or Nigeria !*