

**Southern
Regional
Aquaculture
Center**

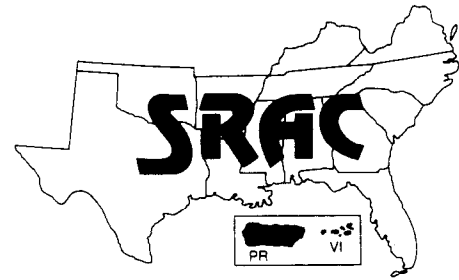

April 1999
Revised

Recirculating Aquaculture Tank Production Systems

A Review of Component Options

Thomas M. Losordo¹, Michael P. Masser² and James E. Rakocy³

There is a great deal of interest in recirculating aquaculture production systems both in the United States and worldwide. Most fish grown in ponds, floating net pens, or raceways can be reared in commercial scale recirculating systems, but the economic feasibility of doing so is not certain. Recirculating systems are generally expensive to build, which increases production cost. (For more information see SRAC publication 456 on the economics of recirculating systems). The challenge to designers of recirculating systems is to maximize production capacity per dollar of capital invested. Components should be designed and integrated into the complete system to reduce cost while maintaining or even improving reliability.

Research and development in recirculating systems has been going on for nearly three decades. There are many alternative technologies for each process and operation. The selection of a particular technology depends upon the species being reared, produc-

tion site infrastructure, production management expertise, and other factors. Prospective users of recirculating aquaculture production systems need to know about the required water treatment processes, the components available for each process, and the technology behind each component. This publication is intended as a starting point for such a study.

A recirculating system maintains an excellent cultural environment while providing adequate feed for optimal growth. Maintaining good water quality is of primary importance in aquaculture. While poor water quality may not be lethal to the crop, it can reduce growth and cause stress that increases the incidence of disease. Critical water characteristics include concentrations of dissolved oxygen, un-ionized ammonia-nitrogen, nitrite-nitrogen, and carbon dioxide. Nitrate concentration, pH, alkalinity and chloride levels also are important.

The by-products of fish metabolism include carbon dioxide, ammonia-nitrogen, and particulate and dissolved fecal solids. Water treatment components must be designed to eliminate the adverse effects of these waste products. In recirculating tank systems, proper water quality is maintained by pumping tank

water through special filtration and aeration or oxygenation equipment. Each component must be designed to work in conjunction with other components of the system. For more information on water quality requirements and management of recirculating systems, see SRAC publications 451 and 452.

Waste solids removal

The decomposition of solid fish waste and uneaten or indigestible feed can use a significant amount of oxygen and produce large quantities of ammonia-nitrogen. There are three categories of waste solids—settleable, suspended, and fine or dissolved solids.

Settleable solids

Settleable solids are generally the easiest to deal with and should be removed from the culture tank water as rapidly as possible. This is easiest when bottom drains are properly placed. In tanks with circular flow patterns (round, octagonal, hexagonal, square with rounded corners) and minimal agitation, settleable solids can be removed as they accumulate in the bottom center of the tank, in a separate, small flow-stream of water, or together with the entire flow leaving the tank. Center drains with two outlets are often

¹Department of Zoology, North Carolina State University

²Department of Wildlife and Fisheries Sciences, Texas A&M University

³University of the Virgin Islands, Agricultural Experiment Station, U.S. Virgin Islands

used for the small flow-stream process. This double drain divides the flow leaving the tank into a small pipe carrying the settleable solids, and a larger pipe with a higher flow rate carrying the suspended solids from the upper water column of the tank (Fig. 1).

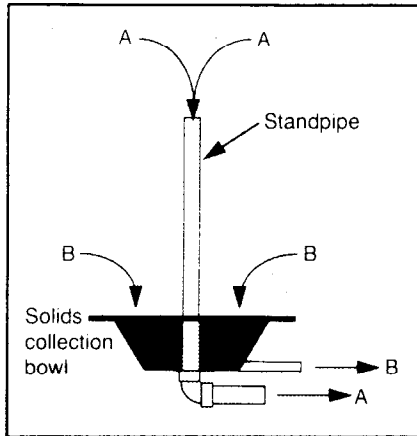

Figure 1. Typical double drain for removing settleable solids from a fish culture tank; A = suspended solids flow stream, B = settleable solids flow stream. (after Losordo, 1997).

Settled solids should be removed from the center of the tank on a continuous or semi-continuous basis. The flow rate at which the settleable solids are carried will determine the method used to collect and concentrate them for further treatment or disposal. In systems with a high settleable solids flow rate (20 to 50 percent of the total tank flow), swirl separators, settling basins, or drum screen filters are used to collect these solids. At lower flow rates, smaller settling components can be used. An example is a double drain developed by Waterline, Inc.¹ (Prince Edward Island, Canada). In this patented design, the flow containing settleable solids moves slowly through a pipe (under the tank) leading to an external standpipe (water level control structure). The flow velocity is slow enough that the solids

¹Mention of a specific product or trade-name does not constitute an endorsement by the authors or the USDA Southern Regional Aquaculture Center, nor does it imply approval to the exclusion of other suitable products.

settle out within the pipe while the clearer water overflows the standpipe. The external standpipe is routinely removed to increase the water velocity in the pipe and the settled solids are flushed from the line.

Another example of a double drain is a particle trap developed at the Center for Scientific and Industrial Research (SINTEF), Norwegian Hydrotechnical Laboratory, in Trondheim, Norway.

In this design, settleable solids flow under a plate, spaced just slightly off the bottom of the tank, in a flow of water that amounts to only 5 percent of the total flow leaving the center of the tank (Flow B, Fig. 2). The larger flow (95 percent of the total) exits the tank through a large discharge strainer mounted at the top of the particle trap (Flow A, Fig. 2). Outside of the tank, the settleable solids flow-stream from the particle trap enters a sludge collector (Flow B, Fig. 3). The waste particles settle and are retained in the sludge collector, and the clarified water exits the sludge collector at the top and flows by gravity for further treatment. The sludge in the collector, which has an average dry weight solids content of 6 percent, is drained from the bottom of the collector.

In rectangular raceways with plug flow (flow that moves along the long axis of the raceway tank), solids are more difficult to remove as the velocity at the bottom of the tank is generally slower than in round tanks. If the water velocity at the tank bottom can be increased to move the settled solids along the bottom of the tank, then solids can be removed using a sediment trap. The sediment trap should span the bottom, across the short axis of the raceway, perpendicular to the direction of water flow. Two reviews of tank flow and hydraulic analysis can be found in Burley and Klapsis (1988) and Tvinnereim (1988).

An alternative to plug flow within a raceway is to create a completely mixed (horizontally and vertically) tank by installing a water inlet and outlet manifold along the long axis of the tank. As seen in Figure 4, water enters uniformly along the bottom of one side of the raceway and is removed along the other side. Water must enter at a high enough velocity to create a rotational flow along the short axis of the raceway (Fig. 4). The solids will move across the bottom of the raceway and into the effluent manifold.

Another method of dealing with settleable solids is to keep them in

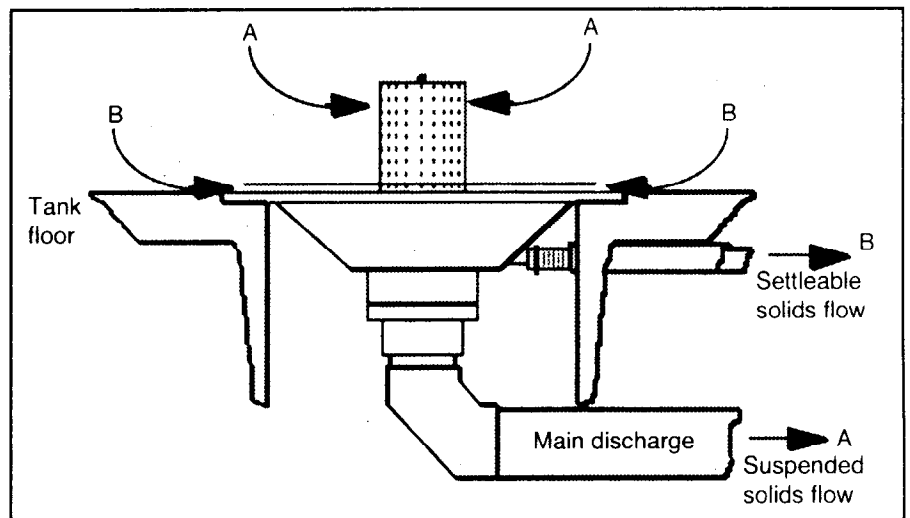

Figure 2. The ECO-TRAPTM particle trap is an advanced double drain design that concentrates much of the settleable solids in only 5 percent of the water flow leaving the fish culture tank (B). (after Hobbs et al., 1997). (ECO-TRAP is a trademark of AquaOptima AS, Pir Senteret, 7005 Trondheim, Norway, U.S. Patent No. 5,636,595.)

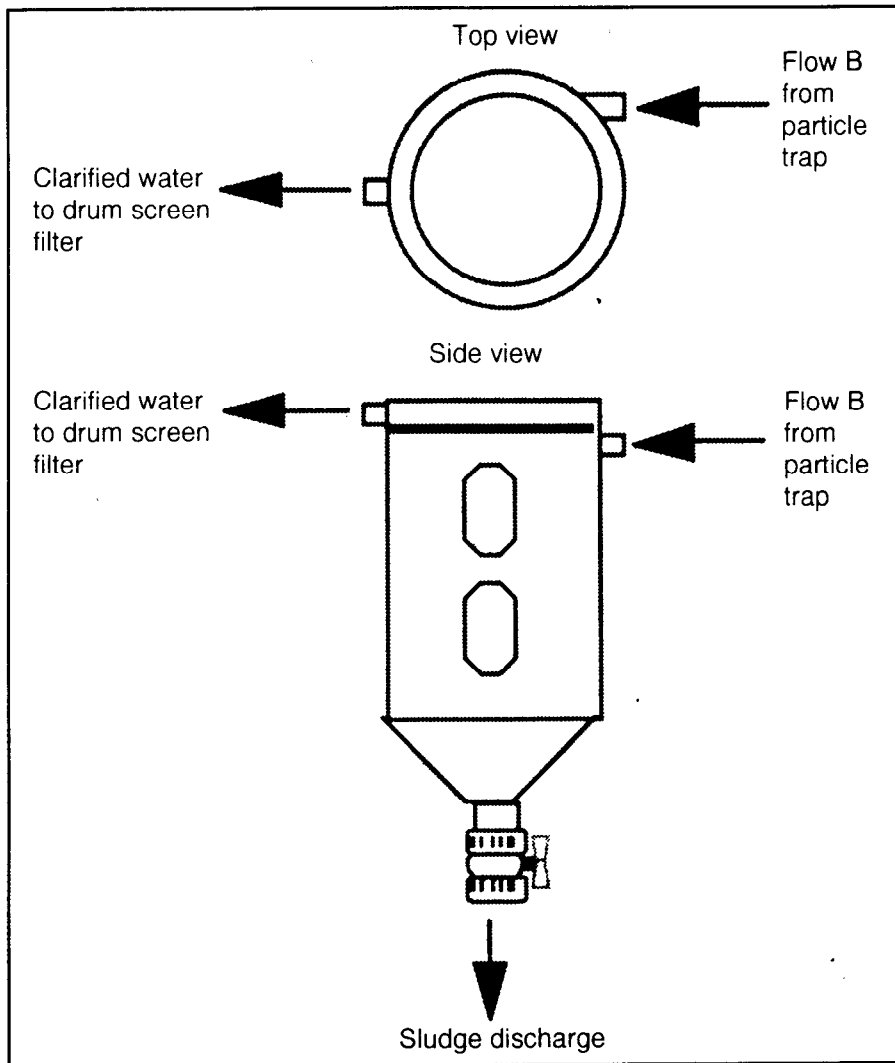

Figure 3. The sludge collector that works in conjunction with the ECO-TRAP™ to remove settled solids from the flow stream B (Fig. 2) (after Hobbs et al., 1997).

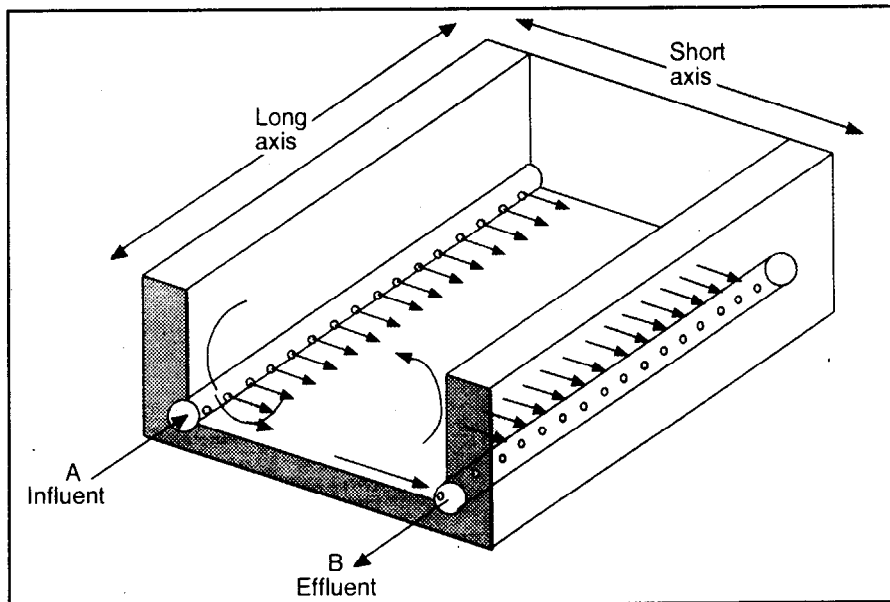

Figure 4. Cross-section of a "cross-flow" raceway. Water flows in through an inlet manifold with jets (A) and out through a similar drain manifold (B) on the opposite side of the tank (after Colt and Watten, 1988).

suspension with continuous agitation until they enter an external settling tank. In settling tanks (or basins), water flow is very slow so that solids settle out by gravity. Settling tanks may or may not include tube or lamella sedimentation material. This material is constructed with bundles of tubes or plates, set at specific angles to the horizontal (usually 60°), that reduce both the settling distance and circulation within the settling tank. Using settling plates reduces the size requirement of a settling basin, thus saving space within a facility. However, the plates make routine cleaning of settling basins more time-consuming.

The benefits of using external settling basins outside of the rearing tank are simplicity of operation, low energy requirements, and the generally low cost of construction. The disadvantages include the relatively large size of settling basins, the time used in routine cleaning, and the large quantity of water that is wasted in the cleaning process. If settling basins are not cleaned regularly, waste solids can break down within the basin and contribute to the ammonia-nitrogen production and oxygen demand of the system.

Another way to remove settleable solids, external to the culture tank, is to use a centrifugal settling component known as a hydrocyclone or swirl separator. In this design, water and particulate solids enter the separator tangentially, creating a circular or swirling flow pattern in a conical shaped tank. The heavier solids move towards the walls and settle to the bottom where they are removed continuously. The main advantage of these units is the compact size. A major disadvantage is the large volume of replacement water required because of the continuous stream of wastewater.

Suspended solids

From an engineering viewpoint, the difference between suspended solids and settleable solids is a practical one. Suspended solids will not easily settle out of the water column in the fish culture

tank. Suspended solids are not always dealt with adequately in recirculating systems. Most current technologies for removing suspended solids generally involve some form of mechanical filtration. Two types of mechanical filtration are screen filtration and expandable granular media filtration.

Screen filtration: Screen filters use some form of fine mesh material (stainless steel or polyester) through which effluent passes while the suspended solids are retained on the screen. Solids are usually removed from the screen by rotating the clogged screen surface past high pressure jets of water. The solids are carried away from the screen in a small stream of waste water. The feature that makes each screen filter different and the challenge in designing these units is the process of collecting the solids on the mesh surface.

The screening material has been used in a disk configuration (Fig. 5A), drum screen configuration (Fig. 5B), and incline belt configuration (Fig. 5C).

In rotating disk filters, water to be treated enters one end of the filter unit and must pass through sequential vertical disks within the filter. A problem with this design is the small amount of screen surface on which to capture solids. In heavily fed production systems, solids can build up so heavily on one side of the filter that the screens collapse from the water pressure.

The most common screen filter is the drum filter (Figs. 5B and 6). With this configuration, water enters the open end of a drum and passes through a screen attached to the circumference of the drum.

In most installations, the drum rotates only when the filter mesh becomes clogged with solids, and

a high pressure jet of water (from the outside of the drum) washes the solids off the screen and into an internal collection trough leading to a waste drain. The advantage of the drum screen filter configuration over the single plate disk filter is the larger surface area of the drum for comparably sized units.

The main advantage of using screen filter technology rather than settling basins and swirl separators is their small size and relatively low water loss during backwashing. Libey (1993) reported that, on average, in a tilapia system, only 13.4 percent of the water used with a settling basin was needed with a drum screen filter.

The main disadvantage of commercial screen filters is cost, especially for smaller units. The smallest commercially available units can process approximately 475 liters per minute (125 gpm) loaded with 25 mg/L of suspended solids, and cost about

\$6,000. A 100 percent increase in processing capacity increases the cost of a unit by about 50 percent (a unit to process 950 liters/minute costs about \$9,000). So, larger units are more cost effective. To take advantage of this, the flow streams from several production tanks can be combined into one treatment stream that is cleaned by a larger drum screen filter. However, the advantage of the economy of scale must be weighed against the risk of spreading disease and water quality problems within linked fish production tanks.

Vacuum cleaned drum screen filters are now in use. These units have limited capacity (375 to 1,800 L/minute, 100 to 475 gpm) and their performance in commercial facilities has not been well documented. Incline screen or belt screen filters also are beginning to

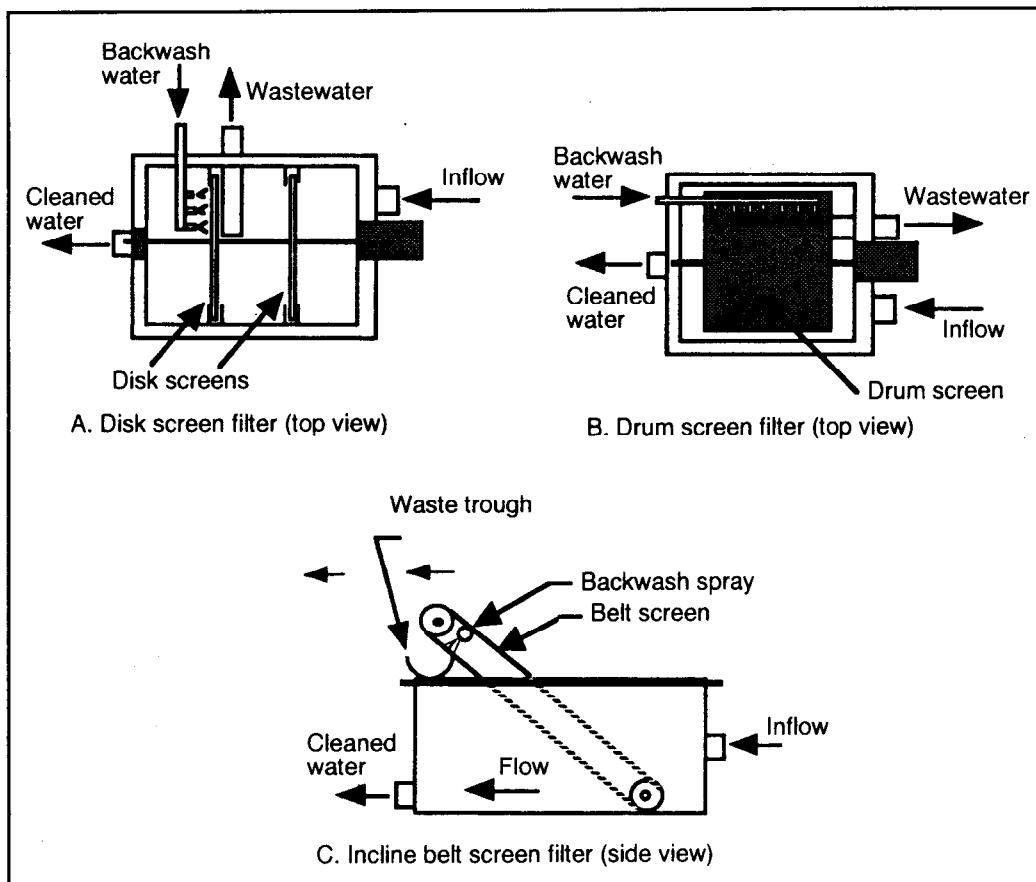

Figure 5. Three screen filter configurations used in recirculating tanks to capture and remove suspended solids.

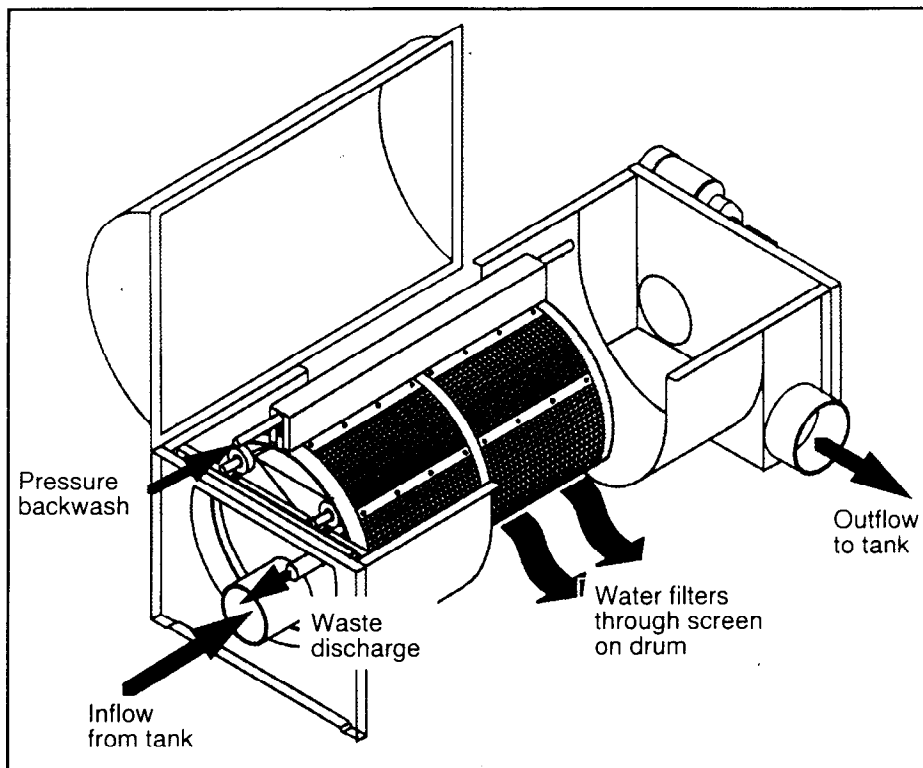

Figure 6. Typical drum screen filter (shown with a cut-away and expanded midsection) for waste solids removal from aquacultural recycle flow streams. (Drawing provided by and used with permission of PRA Manufacturing, Nanaimo, B.C.)

be used in the aquaculture industry (Fig. 5). These units resemble conveyor belts placed on an incline. Water passes through the screen where suspended solids are retained; solids are lifted out of the water on the incline screen and sprayed off with high pressure water in a cleaning process similar to that of disc and drum screen filters. The units manufactured currently have flow capacities in excess of 7,500 liters per minute (1980 gpm). There is little data on the operational characteristics of these filters.

Expandable granular media filtration: Expandable granular media filters remove solids by passing water through a bed of granular medium (sand or plastic beads). The solids either adhere to the medium or are trapped within the open spaces between the medium particles. Over time, the filters will become clogged with solids and require cleaning, or backwashing. Backwashing these filters requires that the filter bed be expanded (from a compacted state) to release the solids. For other applications (e.g., drinking

water, swimming pools), the most common filtration medium is sand. Pressurized down-flow sand filters have been widely used in hatchery operations. While these filters can remove much of the suspended solids in a flow-stream, when fish are fed heavily the filter must be backwashed frequently, which wastes a lot of water. Backwashing these filters is accomplished by reversing the flow of water through the filter medium, causing the bed to expand or "boil." This releases trapped solids and scrapes bacterial growth off the filter medium. However, bacterial growth on the sand eventually creates gelatinous masses within the filters that are impossible to clean with simple backwashing. Then it is necessary to open and manually clean the filter. Down-flow sand filters reduce or stop the flow of water when they clog. Even short-term interruptions of water flow can be disastrous to intensive recirculating systems.

An alternative design, used successfully in the U.S., uses floating plastic beads instead of sand.

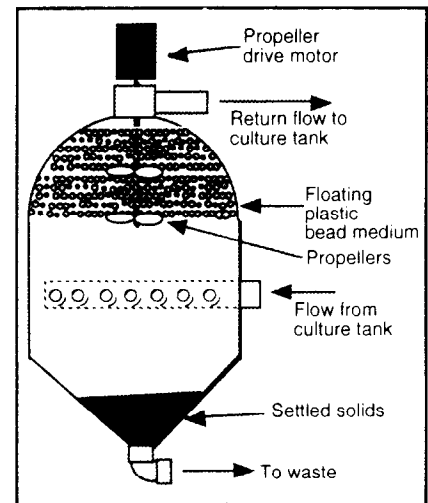

Figure 7. The propeller washed bead filter traps waste solids between the beads and backwashes by expanding the bed of beads with a propeller. (U.S. Patent No. 5,126,042 by Dr. Ronald Malone, Dept. of Civil Engineering, Louisiana State University)

These low density, floating plastic beads trap and remove suspended solids from the flow-stream as the water passes up through a bed of beads (Fig. 7).

The solids are removed by activating a motor that turns a propeller located within the bed of beads. The propeller expands the bed of beads and releases the waste solids that are trapped within it. After the bed expansion period, a short settling period allows the beads to re-float and the solids to settle to the bottom of the filter chamber. A valve is then opened and the settled solids are removed. This sequence of events can be automated with electronic circuits and automated valves. Another bead filter design, referred to as the "bubble washed" bead filter, eliminates the requirement for a propeller to backwash the filter bed. This filter resembles an "hour glass" with two chambers connected by a narrow "washing throat" (Fig. 8).

In the filtration mode, water passes up through the beads while they are in the upper filtration chamber. When the beads need cleaning, the flow is stopped and the filter is drained so that the filter medium drops through the

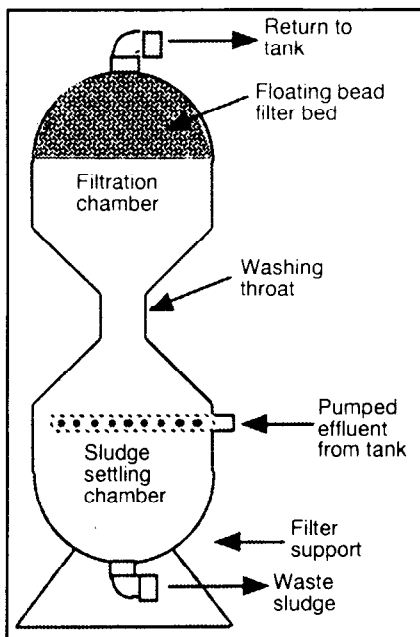

Figure 8. The bubble bead filter operates much like the propeller washed bead filter, except that it backwashes by dropping the filtration medium by gravity through a washing throat. (U.S. Patent No. 5,232,586 by Dr. Ronald Malone, Dept. of Civil Engineering, Louisiana State University)

“washing throat” into the sludge settling chamber. When the flow is re-started, the filter medium floats back into the filter chamber and the waste sludge settles to the bottom of the settling chamber ready for discharge to a waste drain.

The advantage of bead filters is the compact size of the unit and low water use during backwashing. Once biologically active, the beads become sticky and can remove even fine suspended solids. The bacteria that make the filter sticky are a combination of autotrophic and heterotrophic bacteria. The autotrophic bacteria contribute to nitrification. The heterotrophic bacteria break down the organic solids that are trapped within the bead bed. This can be a disadvantage, because during the time between backwashings (1 to 48 hours), solids undergoing bacterial degradation use oxygen from the system water and release ammonia-nitrogen. The oxygen consumed by these bacteria needs to be replaced and the ammonia-

nitrogen produced must be treated.

Fine and dissolved solids

Many of the fine suspended solids and dissolved organic solids that build up within intensive recirculating systems cannot be removed with traditional mechanisms. A process called foam fractionation (also referred to as air-stripping or protein skimming) is often employed to remove and control the build-up of these solids. Foam fractionation is a general term for a process in which air introduced into the bottom of a closed column of water creates foam at the surface of the column. Foam fractionation removes dissolved organic compounds (DOC) from the water column by physically adsorbing DOC on the rising bubbles. Fine particulate solids are trapped within the foam at the top of the column, which can be collected and removed. The main factors affected by the operational design of the foam fractionator are bubble size and contact time between the air bubbles and the DOC. A counter-current design (bubbles rising against a downward flow of water) improves efficiency by lengthening the contact time between the water and the air bubbles (Fig. 9). In this design, water is injected into the foam fractionator through a venturi. The venturi mixes air with the water and the air/water mix-

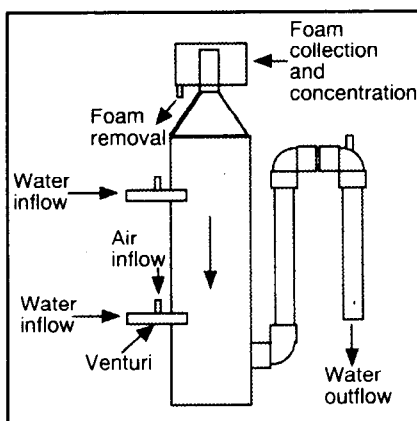

Figure 9. A pump-driven, venturi-type foam fractionator design. A water/air mixture is injected tangentially into the foam fractionator (after Losordo, 1997).

ture enters the body of the foam fractionator tangentially.

Ammonia and nitrite-nitrogen control

Controlling the concentration of un-ionized ammonia-nitrogen (NH_3) in the culture tank is a primary design consideration in recirculating systems. Ammonia-nitrogen (a by-product of the metabolism of protein in feeds) must be removed from the culture tank at a rate equal to the rate it is produced to maintain a stable and acceptable concentration. In systems with external ammonia-nitrogen treatment processes, the efficiency of the ammonia-nitrogen removal process will dictate the recirculating flow rate (e.g., a less efficient removal system will require a higher recycle flow rate from the tank through the filter). There are a number of methods for removing ammonia-nitrogen from water: air stripping, ion exchange, and biological filtration. Air stripping of ammonia-nitrogen through non-flooded (no standing water in the reactor) packed columns requires that the pH of the water be adjusted to above 10 and readjusted to safe levels (7 to 8) before the water re-enters the culture tank. Ion exchange technology is costly and requires a mechanism for “wasting” ammonia-laden salt water. A salt-brine is used to “regenerate” the filter by removing ammonia-nitrogen from the resin (filter medium) once it becomes saturated with ammonia-nitrogen.

Biological filtration is the most widely used method. In biological filtration (or biofiltration); there is a substrate with a high specific surface area (large surface area per unit volume) on which the nitrifying bacteria can attach and grow. Ammonia and nitrite-nitrogen in the recycled water are oxidized (converted) to nitrite and nitrate by *Nitrosomonas* and *Nitrobacter* bacteria, respectively. Commonly used biofilter substrates include gravel, sand, plastic beads, plastic rings, and plastic plates. The most common biofiltration technologies are discussed below.

Rotating biological contactor

Rotating biological contactors (RBC) have been used in the treatment of domestic wastewater for decades, and are now widely used as nitrifying filters in aquaculture applications. RBC technology is based on the rotation of a biofilter medium attached to a shaft, partially submerged in water.

Approximately 40 percent of the substrate is submerged in the recycle water (Fig. 10). Nitrifying bacteria grow on the medium and rotate with the RBC, alternately contacting the nitrogen-rich water and the air. As the RBC rotates, it exchanges carbon dioxide (generated by the bacteria and fish) for oxygen from the air. The tangential velocity of the outer edge of the RBC should be about 35 to 50 feet per minute. For example, an RBC with a diameter of 4 feet would rotate at 3 to 4 revolutions per minute (rpm). The advantages of RBC technology are simplicity of operation, the ability to remove carbon dioxide and add dissolved oxygen, and a self-cleaning capacity. Major disadvantages are the high capital cost and mechanical instability. Poorly designed or built RBCs can break down mechanically with the weight of the biological growth on the filter medium. RBCs also have been designed to be turned by water (similar to a water wheel) and compressed air.

In early aquaculture applications, RBCs had simple discs cut from corrugated fiberglass plate. Now they use media with high specific surface area, such as plastic blocks or a polyethylene tubular medium (resembling hair curlers). These newer plastic media remove more ammonia, nitrite-nitrogen and carbon dioxide in small RBC units. The plastic media have specific surface areas of up to $200 \text{ m}^2/\text{m}^3$ ($69 \text{ ft}^2/\text{ft}^3$). In aquaculture applications, volumetric nitrification rates of approximately $76 \text{ g TAN}/\text{m}^3$ per day can be expected with this type of biological filter (Wheaton et al., 1994). When including these filters in a recirculating system as a nitrifying filter component (assuming 2.5 percent of the feed becomes TAN), a design criterion

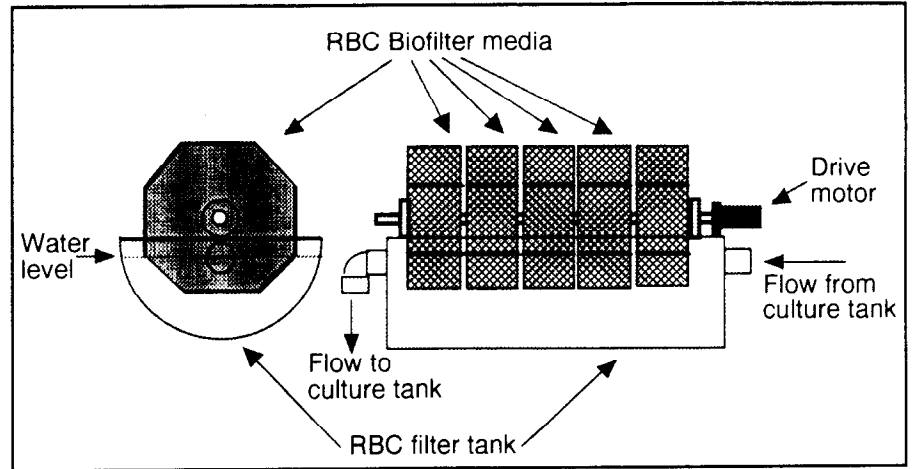

Figure 10. A rotating biological contactor unit powered by an electric gear motor.

of $3.6 \text{ kg feed}/\text{day}/\text{m}^3$ of medium should be used ($0.189 \text{ pounds}/\text{day}/\text{ft}^3$ of medium).

The filter medium increases in weight as much as 10 fold during operation, so the support structure must accommodate the additional weight.

Trickling filters

Trickling filters used in aquaculture systems have evolved from those used in domestic sewage

treatment. This type of filter consists of a water distribution system at the top of a reactor filled with a medium that has a relatively low specific surface area, generally less than $330 \text{ m}^2/\text{m}^3$ ($100 \text{ ft}^2/\text{ft}^3$). This creates large void (air) spaces within the filter medium (Fig. 11). As these filters are operated in a non-flooded configuration, they provide nitrification, aeration, and some carbon dioxide removal in one unit. (The term non-flooded is used to indicate

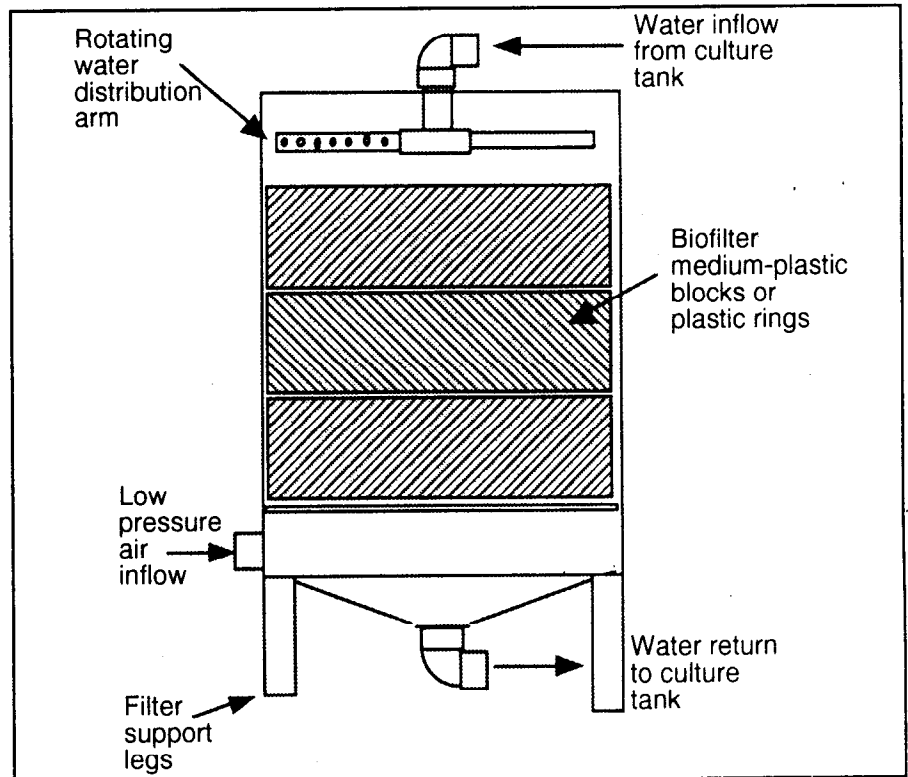

Figure 11. Trickling filters are non-submerged biological filters in which the water is evenly distributed over the medium.

that the biological filter medium is not completely submerged in water). The flow rate through trickling filters is limited by the void space through which water can pass. In general, packing media with more void space can pass a higher rate of flow per square meter of (top) cross sectional surface area. The main disadvantage of trickling filters is that they are relatively large and biofilter media are expensive.

Also, if the recycled water is not prefiltered to remove suspended solids, trickling filters can become clogged over time. As with RBC media, the weight of the biological growth on the filter media should be considered in designing the support structure.

Volumetric nitrification rates of approximately 90 g TAN/m³ per day can be expected with this type of biological filter (Losordo, unpublished data). When designing these filters into a recirculating system as a nitrifying filter component (assuming 2.5 percent of the feed becomes TAN), a design criteria of 3.6 kg feed/day/m³ of medium should be used (0.225 pound/day/ft³ of medium).

Expandable media filters

The expandable media floating bead filters described in the previous section (Figs. 7 and 8 are also used as biofilters in some aquaculture applications. Generally operated as upflow filters, the beads have a high specific surface area on which nitrifying bacteria can colonize. The major advantage of this technology is the combination of nitrification and the solids removal processes into one component. The disadvantage, as noted before, is that solids are held in a place where they can degrade and affect the system's water quality. In general, using these filters will require the designer to provide for more oxygenation and biofiltration capacity. The plastic bead medium used in these filters has a specific surface area of 1,150 to 1,475 m²/m³ (350 to 450 ft²/ft³). Volumetric nitrification rates of approximately 325 g TAN/m³/day can be

expected with this type of biological filter (Beecher et al., 1997). When designing these filters into a recirculating system as a nitrifying and solids removal component (assuming 2.5 percent of the feed becomes TAN), a design criterion of 13 kg of feed/day/m³ of medium should be used (0.81 pounds/day/ft³ of medium; the manufacturer recommends a design rate of 1.0 pound/day/ft³).

Fluidized bed filters

Fluidized bed filters are essentially sand filters operated continuously in the expanded (backwash) mode. Water flows up through a bed of sand at a rate sufficient to lift and expand (fluidize) the bed of sand and keep the sand particles in motion so that they no longer are in continuous contact with each other (Fig. 12).

Fluidized bed filters use sand of smaller diameter than that used in particulate solids removal applications. Plastic beads with densities slightly greater than water also have been used successfully in fluidized bed filters. A fluidized bed filter is an excellent environment for the growth of nitrifying bacteria, and bacteria can colonize the entire surface area of the filter medium. The turbulent environment also keeps the bacteria

sheared from the medium so that the filter is self-cleaning. The main advantage of fluidized bed technology is the high nitrification capacity in a relatively compact unit. The sand also is extremely low cost. Fluidization (pumping) requirements depend upon the size and weight of the medium being used. Keep in mind that the buoyancy of the medium changes with the amount of biological growth on the medium. This, in turn, depends upon the water temperature, nutrient loading rate, and degree of bed fluidization.

Unless there is a system for recovering sand as water leaves the filter, the medium will need to be replaced routinely. Depending upon the temperature, nutrient concentration and size of the medium (and assuming 2.5 percent of the feed becomes TAN), a design criterion of 20 to 40 kg of feed/day/m³ of medium should be used (1.25 to 2.5 pounds/day/ft³ of medium).

Mixed bed reactors

Mixed bed reactors are a new and interesting cross between upflow plastic bead filters and fluidized bed reactors. These filters use a plastic medium kept in a continuous state of movement (Fig. 13).

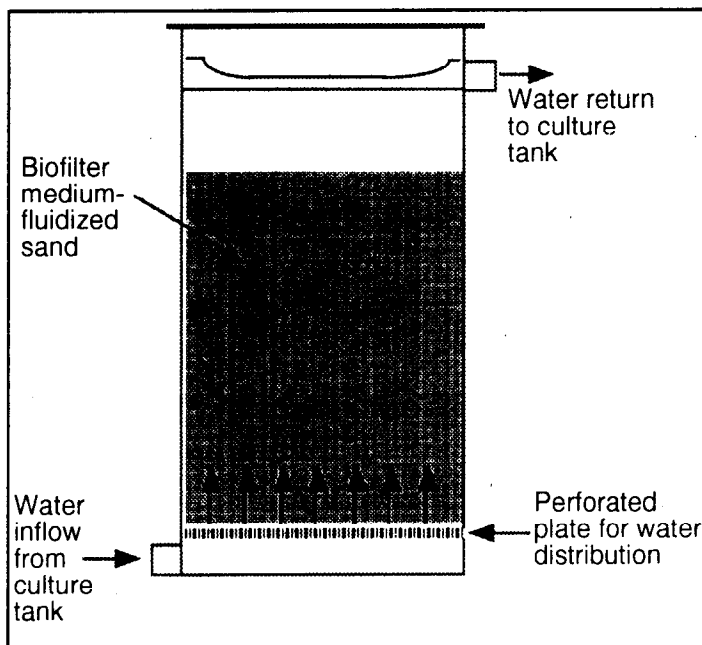

Figure 12. A simplified view of a fluidized sand bed biological filter.

The diameter of the plastic medium is usually much larger than sand, so it has a lower specific surface area (800 to 1,150 m²/m³; 240 to 350 ft²/ft³). The beads are usually neutrally buoyant or just slightly heavier than water. The plastic beads are usually mixed by mechanical or hydraulic means. Mixed bed filters are

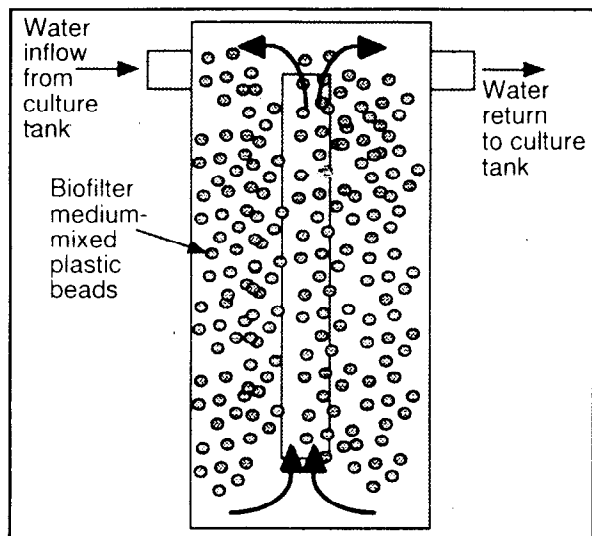

Figure 13. A common configuration for a mixed bed reactor biological filter.

designed as up-flow or down-flow filters and, like fluidized bed filters, they generate biological solids but will not clog because of the continuous movement of the medium. The plastic medium moves through a pipe within the main reactor to vertically mix the bead bed. Depending upon the nutrient concentration and medium size (and assuming 2.5 percent of the feed becomes TAN), a design criterion of 16 to 23 kg of feed/day/m³ of medium should be used (1.0 to 1.4 pounds/day/ft³ of medium).

Dissolved gas

Recirculating systems should maintain adequate dissolved oxygen (DO) concentrations of at least 6 mg/L and keep carbon dioxide (CO₂) concentrations at less than 25 mg/L for best fish growth. Colt and Watten (1988) and Boyd and Watten (1989) discuss aeration and oxygenation systems used in aquaculture; a summary of the component options follows.

The term **aeration** is used here to refer to the dissolution of oxygen from the atmosphere into water. The transfer of pure oxygen gas to water is referred to as **oxygenation**.

Aeration

Diffused aeration: Adding oxygen to a recirculating system by

aerating only the water flowing into the culture tank will not usually supply an adequate amount of oxygen for fish production. The amount of oxygen that can be carried to the fish in this way is limited by the flow rate and the generally low concentration of oxygen in water. Therefore, most aeration in recirculating systems occurs in the culture tank. The most efficient aeration devices are those that move water into contact with the atmosphere (paddlewheels, pro-

peller-aspirators, vertical-lift pumps). However, these methods usually create too much turbulence within a culture tank to be useful. The most common way to aerate in a recirculating tank system is called diffused aeration. Diffused aeration systems provide low pressure air from a "regenerative" type of blower to some form of diffuser near or on the bottom of a culture tank. These diffusers produce small air bubbles that rise through the water column and transfer oxygen from the bubble to the water.

Studies have determined that diffused aeration systems can transfer oxygen at an average rate of 1.3 kg O₂/kW-h (2.15 lbs./hp-hour) under standard (20° C, 0 mg/L DO, clean water) test conditions (Colt and Tchobanoglous, 1979). However, these values must be corrected to account for the actual fish culture conditions. To achieve acceptable fish growth rates, the DO concentration should be kept at 5 mg O₂/L or higher. At water temperatures of 28° C, according to Boyd (1982), the diffuser system's oxygen transfer rate would be only 35 percent of the rate at standard conditions. In this case, the oxygen transfer rate would be reduced to 0.455 kg O₂/kW-h (0.75 lbs./hp-hour). In a well designed recirculating system (one in which solids are removed quickly), the oxygen consumption rate can be estimated as 50 per-

cent of the feed rate (that is, 0.5 kg O₂/kg of feed fed). In a system fed 4.5 kg (10 pounds) of feed over an 18-hour period, the estimated oxygen consumption rate would be approximately 0.125 kg O₂/hour (0.28 pounds/hour). With an actual oxygen transfer efficiency of 0.455 kg O₂/kW-h (0.75 pounds/hp-h), the diffused aeration system would require a blower of approximately 0.275 kw (1/3 hp) to provide an adequate amount of oxygen. If the fish are going to be fed over a shorter period of time, then peak oxygen demand should be estimated and the blower capacity should be increased.

The density of fish production with aeration alone is usually limited to 30 to 40 kg of fish/m³ of culture tank volume (0.25 to 0.33 pounds of fish/gal.). In greenhouse systems where algal blooms are common, oxygen is generated during the daylight hours, and culture densities of up to 60 kg of fish/m³ of culture volume (0.50 pounds of fish/gal.) can be achieved.

Packed column aerators: An ideal location for aerating and degassing water (i.e., removing carbon dioxide) is in the recycle flow-stream just before it re-enters the culture tank. As mentioned previously, however, this method does not usually supply enough oxygen. With submerged biological filtration, the concentration of dissolved oxygen will most likely be lowest and carbon dioxide highest at the outflow of this component. Packed column aerators (PCA) are an effective and simple means of aerating water that is already in a flow-stream. A packed column aerator can be identical in design to a trickling nitrifying filter (Fig. 11). Water is introduced into a reactor filled with medium. Proper design criteria include non-flooded operation and free air exchange through the reactor. Given a PCA influent DO concentration of 4 mg O₂/L, an effective oxygen transfer rate of 0.75 kg O₂/kw-h (1.25 pounds O₂/hp-h) can be attained. While this is a low transfer rate, the true energy cost for using a PCA in combina-

tion with an existing flow-stream is only the energy required to pump water 1.0 to 1.25 meters (3 to 4 feet) to the top of the PCA. If the PCA is to be used for carbon dioxide stripping, a low pressure air blower should be used to force at least five times as much air as water (by volume) up through the PCA medium.

Oxygenation

Pure oxygen is used in recirculating systems when the intensity of production causes the rate of oxygen consumption to exceed the maximum feasible rate of oxygen transfer through aeration. Sources of oxygen gas include compressed oxygen cylinders, liquid oxygen (often referred to as LOX), and on-site oxygen generators. In most applications, the choice is between bulk liquid oxygen and an oxygen generator. The selection of the oxygen source will be a function of the cost of bulk liquid oxygen in your area (usually dependent on your distance from the oxygen production plant) and the reliability of the electrical service needed for generating oxygen on-site.

Adding gaseous oxygen directly into the culture tank through diffusers is not the most efficient way to add pure oxygen gas to water. At best, the efficiency of such systems is less than 40 percent. A number of specialized components have been developed for use in aquaculture applications. For an extensive review of component options, see Boyd and Watten (1989). A review of the more commonly used components follows.

Down-flow bubble contactor: A properly designed low pressure oxygen diffusion system can transfer more than 90 percent of the oxygen injected through the component. One such system is a down-flow bubble contact aerator (DFBC), also referred to as a bicone or a Speece cone. The DFBC system consists of a cone-shaped reactor with a water and oxygen input port at the top (Fig. 14). As the water and oxygen bubbles move down the cone, the flow velocity decreases until it

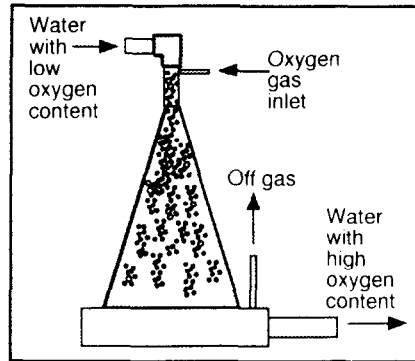

Figure 14. Down-flow bubble contact aerator (after Colt and Watten, 1988).

equals the upward velocity of the bubbles. This allows a long contact time between the water and bubbles and nearly 100 percent absorption of the injected gas. The dissolved oxygen concentration of water leaving a DFBC can be as high as 25 mg/L given a system pressure of approximately 1 bar (14.7 PSI).

U-tube diffusers: At high operating pressures, more oxygen can be absorbed by water. A u-tube oxygen diffusion system is an energy efficient method of adding pressure to a flow-stream. A typical u-tube consists of a contact loop, usually a pipe within a pipe (Fig. 15), buried in the ground to at least 10 meters (33 feet), the height of water required to add one atmosphere of pressure (1 bar, 14.7 PSI). The contact loop is placed below tank level to minimize energy requirements, rather than pumping water up hill to gain the extra hydrostatic pressure created by a column of water. Oxygen is mixed with the water at the entrance to the u-tube and travels with the flow to the bottom of the water column. The additional pressure from the water column accelerates the rate of oxygen absorption into the water. The principal advantages of this system are the low energy requirements for oxygenating large flow-streams and the resistance to clogging with particulate solids. The major disadvantage is the construction cost of drilling the shaft and installing the u-tube. Oxygen transfer efficiencies are generally below 70 percent, with effluent oxygen concentrations of

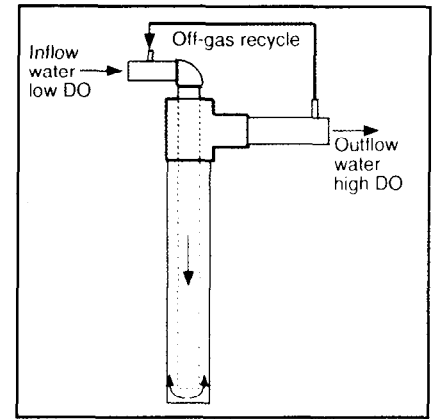

Figure 15. Typical u-tube oxygen diffusion design.

up to 250 percent of atmospheric saturation (15 to 20 mg/L).

Low head oxygenation system:

The multi-staged low head oxygenator (LHO) oxygenates flowing water where there is only a small elevation difference between the source of the water and the culture tank. This situation is often found in raceway systems set up in series. That is, the outflow of one raceway is just slightly (1 to 3 feet) above the inflow of an adjacent raceway. This technology is a patented component (U.S. Patent No. 4,880,445; Water Management Technologies, P.O. Box 66125, Baton Rouge, LA) and is made up of a perforated, horizontal distribution plate and multiple, adjacent, vertical contact chambers (Fig. 16). Pure gaseous oxygen enters one (end) contact chamber and oxygen with off-gases (nitrogen and CO₂) exits the adjacent contact chamber.

The oxygen transfer capability of this system is determined by the length of water fall, gas and water flow rates, the DO concentration of the influent water, and the number of contact chambers (Watten 1994). Including packing medium in the contact chambers can improve performance.

Pressurized packed columns:

Pressurized packed columns are usually operated in a flooded mode (water fills the reactor). Water enters the top of a pressurized chamber that contains a medium with a high specific surface area (much like packed towers). Oxygen gas is usually intro-

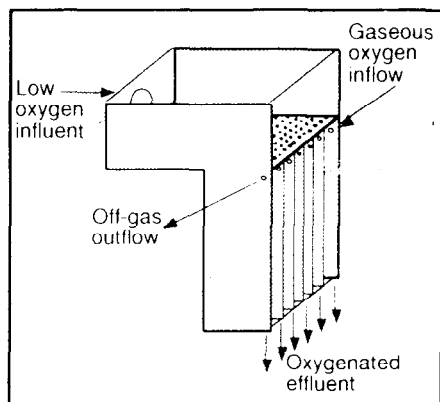

Figure 16. Multi-staged low head oxygenator with front plate removed to show component detail (after Losordo, 1997).

duced at the bottom of the column and travels upward, counter to the water flow. Oxygen transfer efficiency can range from 50 to 90 percent with effluent dissolved oxygen concentrations in excess of 100 mg/L. The major disadvantages of this system are high energy requirements (to provide the pressure) and the buildup of biological growth on the packing medium, which makes periodic cleaning necessary.

Disinfection

Diseases can spread quickly because of the density of fish in recirculating systems. Some chemicals used to treat diseases have a devastating effect on the nitrifying bacteria within the biofilter and culture system. Alternatives to traditional chemical or antibiotic treatments include the continuous disinfection of the recycled water with ozone or ultraviolet irradiation. For more information on disease treatment in recirculating systems, see SRAC publication 452 on the management of recirculating systems.

Ultraviolet irradiation

Microorganisms (including disease-causing bacteria) are killed when exposed to the proper amount of ultraviolet (UV) radiation. Spotte (1979) notes that the effectiveness of UV sterilization depends upon the size of the organism, the amount of UV radi-

ation, and the level of penetration of the radiation into the water. To be effective, microorganisms must come in close proximity to the UV radiation source (0.5 cm, 0.2 inches or less). Turbidity reduces its effectiveness. For a UV radiation system to be effective, the water should be pre-filtered with some form of particulate filtration device.

The most popular and effective type of UV sterilization unit is one with a submerged UV radiation source. In this type of unit, recycled water passes by an elongated UV lamp (much like a neon light bulb). The lamp is inside a quartz glass, watertight jacket and does not come in direct contact with the water. The UV lamp and quartz tube are held within a small diameter pipe through which the treated water flows. As water passes along and around the UV lamp, microorganisms are exposed to the UV radiation. Keeping the quartz jacket clean is imperative to the proper operation of the unit. UV sterilization units are usually rated by their manufacturers according to their water flow rate capacity. Increased efficiency can be achieved by reducing the flow rate through a given unit. The main disadvantage of UV sterilization is the need for clean water with low suspended solids concentrations. Clear water is not always economically achievable in heavily fed recirculating systems. Additionally, the expensive UV lamp must be replaced periodically. The main advantage of UV sterilization is that it is safe to operate and is not harmful to the cultured species.

Ozonation

Ozone (O_3) gas is a strong oxidizing agent in water. Ozone has been used for years to disinfect drinking water. However, because of the high levels of dissolved and suspended organic materials in recirculating systems, the effect of ozone on bacterial populations is questionable (Brazil et al., 1996). The efficiency of the disinfecting action depends upon the contact time and residual concentration of

O_3 in the water with the microorganisms. Ozone must be generated on-site because it is unstable and breaks down in 10 to 20 minutes. Ozone is usually generated with either a UV light or a corona electric discharge source. There are many commercial ozone generation units available.

Ozone is usually diffused into the water of a recirculating system in an external contact basin or loop. Water must be retained in this side-stream long enough to ensure that microorganisms are killed and the ozone molecules are destroyed. Residual ozone entering the culture tank can be very toxic to crustaceans and fish. Ozone in the air is also toxic to humans in low concentrations. Great care should be taken in venting excess ozone from the generation, delivery, and contact system to the outside of the building. Ozonation systems should be designed and installed by experienced personnel.

Summary

This publication has outlined the major components and options used in recirculating aquaculture production systems. This is by no means a complete listing, new technologies are continually being developed. One should not attempt to simply link the components discussed here and expect to have a properly operating system. Any system you buy should be the result of years of development, with each component properly sized and integrated for optimal performance. When reviewing your options, always seek the assistance of a knowledgeable, experienced person, one who has designed a currently operating and economically viable recirculating fish production system.

References and suggested readings

- Boyd, C.E. 1982. Water quality management for fish pond culture. Elsevier Scientific Publishing Company, Amsterdam, the Netherlands.

- Boyd, C.E. 1991. Types of aeration and design considerations. In: L. Swann (editor), Proceedings of the Second Annual Workshop: Commercial Aquaculture Using Water Recirculating Systems. Illinois State University, Normal, Illinois. Nov. 15-16, 1991. pp. 39-47.
- Boyd, C.E. and B.J. Watten. 1989. Aeration systems in aquaculture. *CRC Critical Reviews in Aquatic Sciences* 1: 425 - 472.
- Brazil, B.L., S.T. Summerfelt and G.S. Libey. Applications of ozone to recirculating aquaculture systems. In: G.S. Libey and M.B. Timmons (editors), Successes and Failures in Commercial Recirculating Aquaculture. Proceeding from the Successes and Failures in Commercial Recirculating Aquaculture Conference. Roanoke, VA. July 19-21, 1996. NRAES-98. Northeast Regional Agricultural Engineering Service, 152 Riley-Robb Hall, Ithaca, NY, pp. 373-389.
- Burley, R. and A. Klapsis. 1988. Making the most of your flow (in fish rearing tanks). In: Proceedings of the Conference: Aquaculture Engineering: Technologies for the Future, Sterling Scotland. IChemE Symposium Series #111, EFCE Publications Series # 66, Rugby, UK. pp. 211-239.
- Colt, J.E. and G. Tchobanoglous. 1979. Design of aeration systems for aquaculture. Department of Civil Engineering, University of California, Davis, CA.
- Colt, J. and B. Watten. 1988. Applications of pure oxygen in fish culture. *Aquacultural Engineering* 7:397-441.
- Grace, G.R. and R.H. Piedrahita. 1989. Carbon dioxide removal in a packed column aerator. Presented paper at the International Summer Meeting of Am. Soc. Ag. Eng. and Can. Soc. Ag. Eng., June 25-28, 1989, Quebec, PQ, Canada.
- Hobbs, A., T. Losordo, D. DeLong, J. Regan, S. Bennett, R. Gron and B. Foster. 1997. A commercial, public demonstration of recirculating aquaculture technology: The CP&L/EPRI Fish Barn at North Carolina State University. In: M.B. Timmons and T.M. Losordo (editors). Advances in aquacultural engineering. Proceedings from the aquacultural engineering society technical sessions at the fourth international symposium on tilapia in aquaculture. NRAES-105. Northeast Regional Agricultural Engineering Service, 152 Riley-Robb Hall, Ithaca, NY. pp. 151-158.
- Huguenin, J.E. and J. Colt. 1989. Design and operating guide for aquaculture seawater systems. Elsevier Scientific Publishers, Amsterdam, The Netherlands.
- Libey, G.S. 1993. Evaluation of a drum filter for removal of solids from a recirculating aquaculture system. In: J.K. Wang (editor), Techniques for Modern Aquaculture. Proceedings of an Aquacultural Engineering Conference. Spokane, WA, June 1993. American Society of Agricultural Engineers, St. Joseph, MI. pp. 519-532.
- Losordo, T.M. 1997. Tilapia culture in intensive recirculating systems. In: Costa-Pierce, B. and Rakocy, J. (editors), Tilapia Aquaculture in the Americas, Volume 1. World Aquaculture Society, Baton Rouge, LA. pp. 185-208.
- Malone R.F. and D.G. Burden. 1988. Design of recirculating soft crawfish shedding systems. Louisiana Sea Grant College Program, Louisiana State University, Baton Rouge, LA.
- Spotte, S. 1979. Fish and invertebrate culture: Water management in closed systems. John Wiley & Sons, New York, NY.
- Timmons M.B. and T.M. Losordo (editors). Aquaculture water reuse systems: Engineering, design and management. Developments in Fisheries Sciences 27. Elsevier Scientific Publishing Company, Amsterdam, The Netherlands.
- Tvinnereim, K. 1988. Design of water inlets for closed fish farms. In: Proceedings of the Conference: Aquaculture Engineering: Technologies for the Future. Sterling Scotland. IChemE Symposium Series #111, EFCE Publications Series # 66, Rugby, UK. pp. 241-249.
- Watten, B.J. 1994. Aeration and oxygenation. In: M.B. Timmons and T.M. Losordo (editors), Aquaculture water reuse systems: Engineering, design and management. Developments in Fisheries Sciences 27. Elsevier Scientific Publishing Company, Amsterdam, The Netherlands.
- Wheaton, F.W., J.N. Hochheimer, G.E. Kaiser, R.F. Malone, M.J. Krones, G.S. Libey and C.C. Estes. 1994. Nitrofication filter design methods. In: Timmons, M.B. and T. M. Losordo (editors), Aquaculture water reuse systems: Engineering, design and management. Developments in Fisheries Sciences 27. Elsevier Scientific Publishing Company, Amsterdam, The Netherlands. pp. 125-171.