

Southern Regional Aquaculture Center

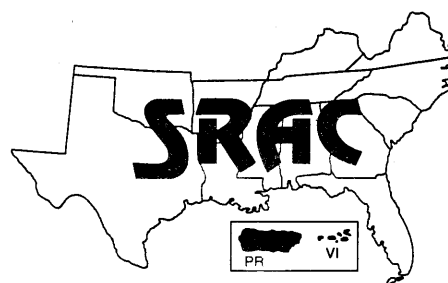

April 1997
Revised

Cage Culture

Cage Construction, Placement, and Aeration

Michael P. Masser*

Cages for fish culture have been constructed from a variety of materials and in practically every shape and size imaginable. Basic cage construction requires that cage materials be strong, durable, and non-toxic. The cage must retain the fish yet allow maximum circulation of water through the cage. Adequate water circulation is critical to the health of the fish, in bringing oxygen into the cage, and removing wastes from the cage. Location of the cage in the pond is critical to proper circulation through the cage. Mechanical circulation and aeration through the cage may be necessary if stocking densities are high (Figure 1), cages are large, or water quality deteriorates during production (see SRAC Publication No. 161, *Cage Culture – Site Selection and Water Quality*).

Cage materials

Cage components consist of a frame, mesh or netting, feeding ring, lid, and flotation. Cage shape may be round, square, or rectangular. Shape does not appear to affect production with most freshwater species.

Cage size depends on the size of the pond, the availability of aeration, and the method of harvest. Most fish farming supply companies sell manufactured cages, cage kits, or materials for constructing cages. The most common cage sizes utilized in ponds are: cylindrical—4x4 (diameter x depth) feet; square—4x4x4 feet and 8x8x4 feet (length x width x depth); and rectangular—8x4x4 and 12x6x4 feet (see figures).

The frame of the cage can be constructed from wood (preferably redwood or cypress), iron, steel, aluminum, fiberglass, or PVC. Frames of wood, iron, and steel (unless galvanized) should be coated with a water-resistant substance like epoxy, or an asphalt-based or swimming pool paint.

Bolts or other fasteners used to construct the cage should be of rust-resistant materials. Mesh or netting materials that can be used include plastic coated welded wire, solid plastic mesh, and nylon netting (knotted or knottless). Mesh size should be no smaller than 1/2 inch to assure good water circulation through the cage while holding relatively small fingerlings (4 to 5 inch) at the start of the production cycle. A larger mesh size can be used if large fingerlings are stocked. The feeding ring or collar can be made of 1/8- or 3/16-inch mesh and should be 12 to 15 inches in width. The feeding ring keeps the floating feed from washing through the cage sides.

All cages should have lids to assure that fish do not escape and that predators (including people) do not have access to the cage. Lids may be made from the same mesh material as the rest of the cage or can be made of other materials, such as plywood, masonite, or light gauge aluminum or steel. Plywood, masonite, and steel will need to be painted with exterior or epoxy paint. Some cage enthusiasts believe that opaque lids (particularly in clear ponds) reduce stress on fish by limiting their visual



Fig. 1. Caged fish are held at extremely high densities. Example shows catfish at seven per cubic foot.

*Extension Fisheries Specialist, Alabama Cooperative Extension System, Auburn University, AL.

contact with outside disturbances. No scientific research has been performed to support or dispute this observation. It should be remembered, however, that the manager of the cage needs to be able to observe feeding behavior and have easy access to the cage to remove uneaten feed and any dead fish.

Flotation of the cage can be provided by styrofoam, water-proofed foam rubber, sealed PVC pipe, or plastic bottles. Cages can also be suspended from docks. Plastic bottles should be made of sturdy plastic (e.g., antifreeze or bleach bottles) and should have their caps waterproofed with silicon sealer. Floats should be placed around the cage so that it floats evenly with the lid about 6 inches out of the water.

Cage construction

The simplest cage design to construct is a 4x4 feet cylindrical cage fashioned from 1/2-inch plastic mesh (Figure 2). The mesh comes in a roll 4 feet wide, and a total of 21 feet of plastic mesh is used per cage. Thirteen feet of mesh is used for the cylinder with two 4-foot panels for the bottom and lid. The cylinder is formed around two metal, PVC, polypropylene, or fiberglass hoops at the top and bottom of the cage. A third hoop is used to form the lid. Cages can be laced together with 18-gauge bell wire (plastic coated solid copper wire), stainless steel wire, hog rings, or black plastic cable ties (white

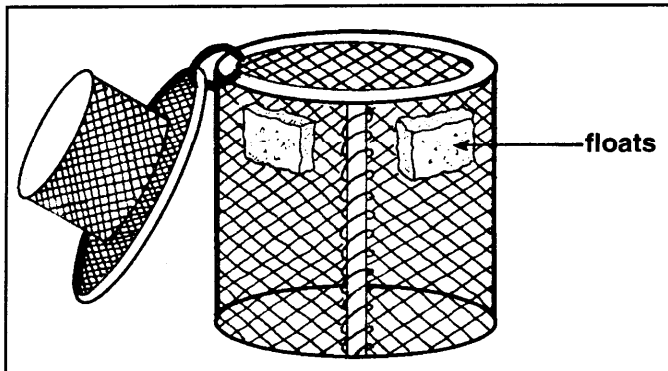

Fig. 2. The 4' x 4' cylindrical cage design.

cable ties should not be used as they deteriorate in sunlight). For detailed instructions on the design of a 4x4 round cage see SRAC Publication No. 340, *4-H Aquatic Science Project, Guide to Raising Catfish in a Cage* and Publication No. 341, *4-H Aquatic Science - Catfish Cage Culture Record Keeping Project*.

Figure 3 shows the design of a 12x6x4 cage which is popular in commercial cage culture of catfish. These cages are usually made from coated (a commercially available plastic net coating) knotted nylon netting and floated with a 4-inch PVC frame. Lead weights along the bottom seams of the cage maintain the cage's shape in the water.

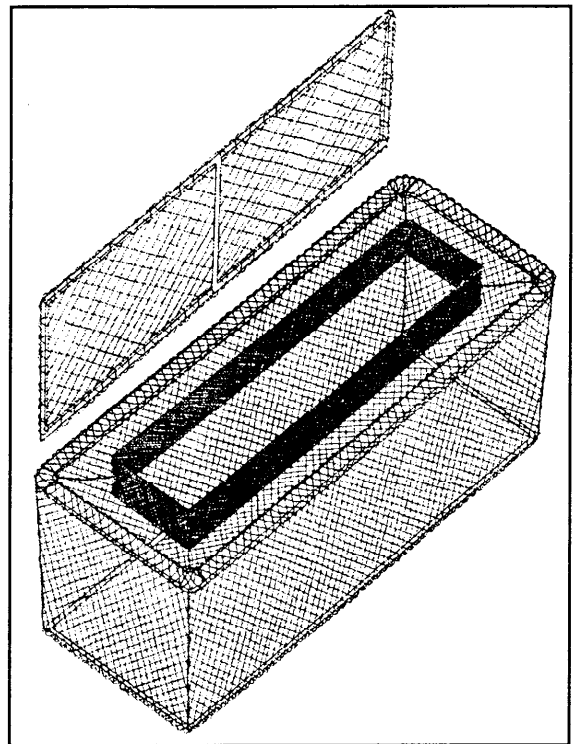

Fig. 3. The 12' x 6' x 4' commercial cage design.

All cages need feeding rings to keep floating feed inside the cage. Feeding rings should be about 15 inches in width and should be attached to the cage so as to extend 3 inches above the water level with 12 inches extending into the water. Feeding rings can be attached to the cage or suspended from the lid. Suspending the feeding ring from the lid reduces the amount of fouling around the sides of the cage. The feeding ring is prone to fouling because of its smaller mesh size. Even with a feeding ring some feed will be washed out of the cage by aggressively feeding fish.

it is probably better to construct a removable feeding tray with 3-inch or higher sides (to keep feed from being swept off the tray by the swimming action of the fish). Feed can be dropped into the cage above the tray and the tray can be removed to check for feeding response and cleaned as needed.

Cage lids should be attached so they are not readily dislodged by wouldbe predators yet can be easily opened to remove dead fish. Lids are commonly attached so that they hinge along one side of the cage and are wired or hooked along the other sides for easy access.

Some cages have been constructed with solid or fine mesh bottoms so that sinking feed can be fed during cold weather. Fouling has been observed as a problem with these cages. If sinking feed is going to be fed,

Cage placement

Location of the cage in the pond can be critical to its success. Two factors to consider in cage placement are access to the cage and maintenance of water quality. Daily feeding and management of the cage necessitate easy access under almost any weather condition. Access may be by pier or by boat. Probably more critical to the success of the cage will be a location in the pond that allows for good water circulation.

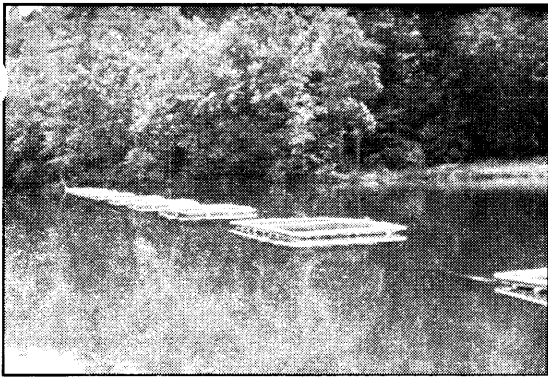

Fig. 4. Cages properly separated across pond with no pier.

Critical factors

Critical factors for locating a cage to maximize water quality are:

Windswept. It is important that the cage be in an area where it will receive maximum natural circulation of water through the cage. Usually, this is in an area that is swept by the prevailing winds (usually prevailing summer winds are from the southwest).

At least 6 feet of water depth. A minimum of 2 feet of water is needed under the cage to keep cage wastes away from the fish.

Away from coves and weed beds. Coves, weed beds and overhanging trees can reduce wind circulation and potentially cause problems.

Away from frequent disturbances from people and/or other animals (e.g., dogs, ducks, etc.) Disturbances from people frequently walking on the dock, fishing or swimming near the cage,

and/or from animals which frequent that area of the pond will excite the fish and can cause stress, injury, reduced feeding, and secondary disease. Fish are shy creatures and should never be disturbed needlessly.

At least 10 feet between cages (unless aeration is available). Cages should not be too close together (Figure 4). Close proximity to other cages may increase the likelihood of low dissolved oxygen (See SRAC Publication No. 161, *Cage Culture – Site Selection and Water Quality*) and spread of diseases between cages.

Access to electricity or to a location where a tractor-driven paddlewheel, irrigation pump, or other aeration device can deliver aerated water to the cages should be considered when locating cages.

Aeration

Aeration can enhance water quality, reduce stress, improve feed conversion efficiency, and increase growth and production rates. Research has shown that aeration can improve cage production by 20 percent or more. Aeration is most commonly needed at night or during still, overcast days. Aeration for cages can be provided by several types of mechanical aerators. The key to aeration of cages is to create a current that moves water through the cage. Mechanical aerators like paddlewheels, vertical

pumps, or propeller-aspirators can be placed near cages where they create currents through the cages. These types of aerators work well to aerate cages near them and within their current pattern. However, aerators may not work well in creating currents that aerate multiple cages, particularly cages staggered along both sides of a pier.

Air-lift pumps powered by high-volume, low-pressure regenerative blowers can be an efficient and cost effective means of aerating many cages spaced along a pier. Placing air stones in cages appears to agitate and stress catfish, while aerated water pouring into the top of the cage from air-lifts does not disturb them. Figure 5 shows how air-lifts can be constructed from 3-inch (or 4-inch) PVC pipe and connected by 5/8-inch garden hose to a 2-inch or larger air supply manifold attached to the pier. Each air-lift will move approximately 60 gallons per minute into the cage. One air-lift is usually sufficient to aerate a single small cage (4x4 or 6x6 foot cages), but larger cages (12x6 feet) need 2 or more air-lifts.

As many as 27 air-lifts can be powered from a single 1-horsepower regenerative blower. The keys to using multiple air-lifts in multiple cages are:

- construct all air-lifts to exact dimensions (so all are identical), place or attach all air-lifts at the same depth in relation to the water surface, and

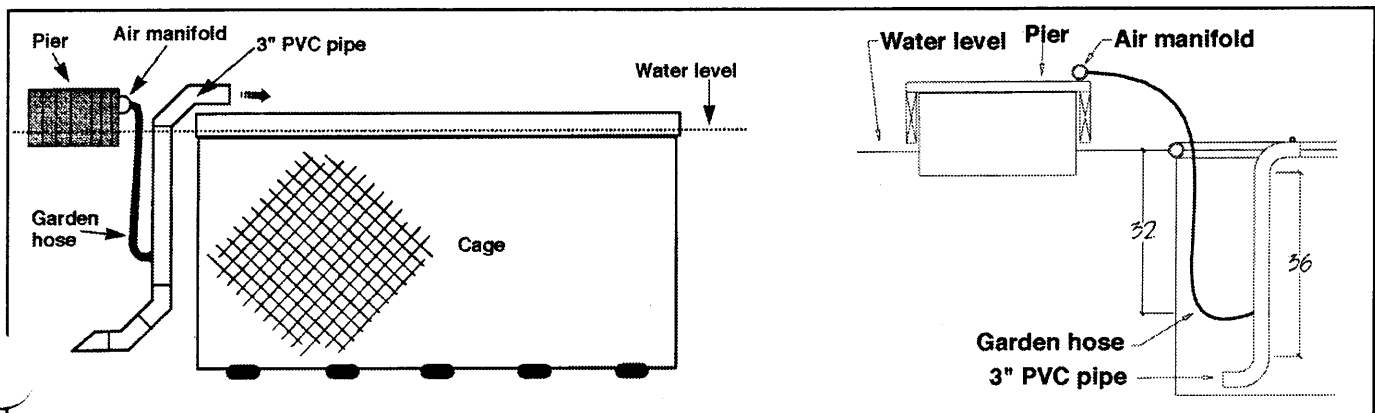

Fig. 5. Cage along a pier with air-lifts mounted over the top of the case (left) and inside the cage (right).

- construct restriction orifices at the connection of the air manifold and the air line (going to each air-lift).

Most air-lifts should be constructed to be approximately 36 inches long with an "elbow" at the upper end (elbows at the bottom are optional). Air-lifts can be attached to the outside of the cage or hung in the cage (see Figure 6). Air-lifts will not lift water more than a few inches above the pond's surface and therefore should be attached to the cage as close to the water surface as possible. Air-lifts must be attached to the cage(s) at the same level and held straight vertically, not tilted. The place the hose connects to the air-lift must be between 30 and 34 inches below water level, and all air-lifts must have hoses attached at the same level. A constriction orifice (see Figure 7) must be placed in the air line going to each air-lift, where it attaches to the air manifold. Orifice size should be between 1/8 and 3/16 inch in diameter (3/16-inch diameter is common) and all the same size. The constriction orifice equally distributes air to all air-lifts and stabilizes water flow through each air-lift.

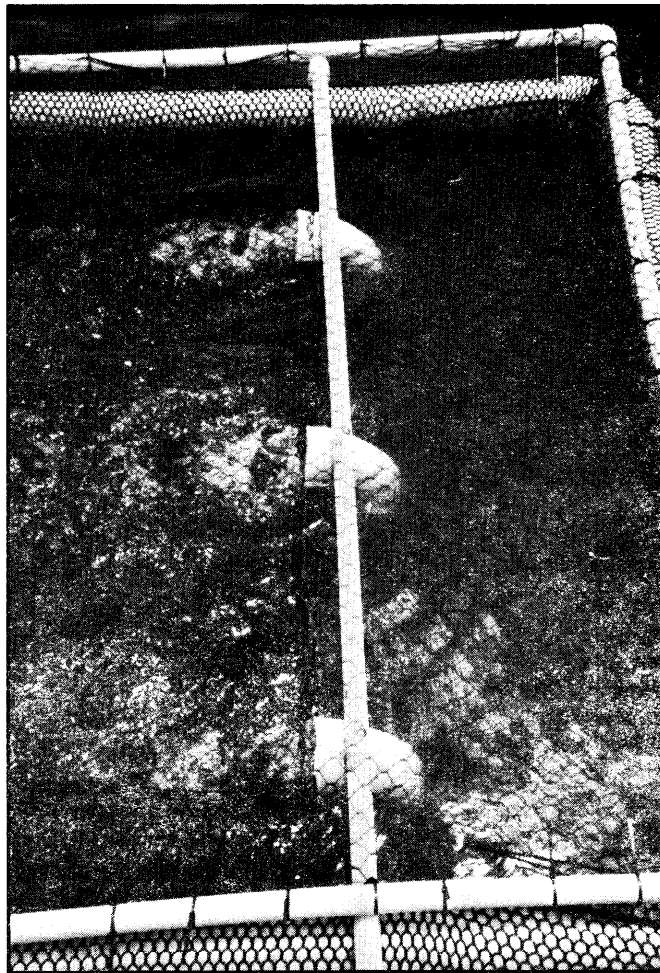

Fig. 6. Air-lifts inside cage.

Large cages

Larger cages than the ones described here have been built and utilized particularly in large lakes, reservoirs, rivers, bays, and estuaries. Many times large cages are called net pens because they are constructed from nylon netting. Most commercial ventures in warmwater cage culture using large cages (e.g., 20x20x12) have failed. Most of these failures appear to have been caused by water quality and associated disease problems. Some research and demonstration projects have been conducted in the southeastern states using large cages with aeration devices. These aerated cages have worked well in producing fish but little effort has been made

to evaluate the cost effectiveness of these systems. It would appear, however, that large cages can be designed which will maximize the number of fish sustainable by the pond and actually support increased densities above present recommended levels by including aeration systems in the design. For further information on these cages contact your state Extension fisheries or aquaculture specialist.

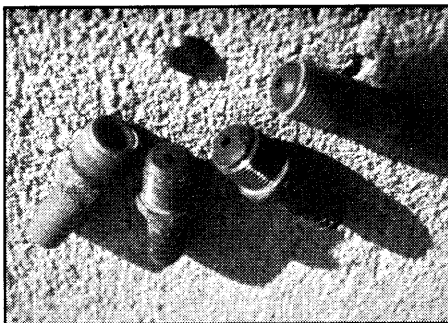

Fig. 7. PVC tubing connectors with constriction orifice.

