



[SUBSCRIBE NOW](#) [RENEW ONLINE](#) [SHOPPING](#) [CUSTOMER SERVICE](#)

Issue # 91- January/February 1985

## MAKE YOUR OWN COLD-WEATHER CLOTHING

If you love the feel of winter wind on your cheeks but don't want to spend your last cold dime...

Michael Rutter

When most of us think of a winter vacation, we dream of sunny tropical islands with white sand and gentle breakers. When Jim Philips headed off on his snow season voyage, though, he went several hundred miles above the Arctic Circle ... to a deserted place on the frozen ice north of Point Barrow, Alaska.

To make this "dream trip" more unusual, Jim Philips didn't dress in the latest cold-weather wear from L.L. Bean or Eddie Bauer. Instead, he and his father wore winter clothing (and even used sleeping systems and mukluks) that they developed and made for under \$100!

The pair started to design their own clothing when Jim was a boy. "When I was in Boy Scouts," Jim says, "I could barely afford what was offered on the market for winter camping. Then, when I did spend a lot of money on something that was supposed to be 'winterproof' and it didn't do the job, I was so disappointed that I decided to make some gear myself."

Jim adds that he didn't just get out of bed one day and decide to go camping on the polar ice cap. In fact, that expedition was the ultimate challenge after years of testing. Previously, Jim and his father had camped in subzero temperatures at 13,000 feet in the Colorado Rockies and in blizzards on the infamous Mount Washington in New Hampshire, to name a couple of chilly spots.

I asked Jim how he could stay warm without the standard equipment that seems so essential to winter survival. Immediately he corrected me. "Survival," he said, "is the wrong word. I prefer to use the word living in reference to arctic conditions. A person can survive but be uncomfortable, perhaps get frostbitten and lose limbs. That's not good enough for me. You should be able to stay warm and not suffer adverse effects. The clothes I've developed aren't fancy, but they work because they insulate, they breathe, and they're practical."

Making cozy-in-the-cold clothing like Jim's is both easy and inexpensive. You need no special tools or sewing skills for the job. Just gather up a 4' X 8' piece of 1" supersoft polyurethane plastic foam (foam rubber and other substitutes will not work), a very large shirt and pair of pants, a sharp knife, a supply of Velcro strips, and an aerosol can of urethane glue.

One-inch foam can be purchased from an upholstery supply store for about 30¢ a linear foot. This is the ideal thickness for living and working in subzero temperatures and is recommended for the pants and torso sections of your clothing. You can use thinner foam, 5/8" or 3/4", for the arms.

Be sure that the shirt and pants are at least four or five sizes larger than you normally wear and made of a fabric, such as double-knit polyester, that doesn't absorb water.

ARE YOU READY?

Using Fig. 1 as a rough guide, cut the pants from a single piece of large foam with a sharp knife (a dull blade grabs and pulls the foam). Use long sweeping motions to make clean, smooth cuts; cut the foam bigger than necessary, then trim to fit your needs. The belt-line should be 6" larger than the normal size. (The drawing gives the measurements for a man with

Search the Archiv

[Subscribe](#)  
[Customer Service](#)  
[Change Your Address](#)  
[Renew](#)  
[Gift Subscription](#)

[Mother Earth Tips](#)  
[Mother Earth Archive](#)  
[Mother Earth Forums](#)  
[Mother Earth Shopping](#)

[Hot Topics](#)  
[Publishers Blog:](#)  
[Green Acres](#)  
[Classified Ads](#)  
[Events](#)  
[Free Product Info](#)

[Home](#)  
[Contact Us](#)  
[Site Map](#)

### Today's Most Read Articles

1. [Kit Homes](#)
2. [Down to Earth Homes](#)
3. [Make a Sack That's Better Than Santas! "Duffel Up" For Christmas](#)
4. [Oil-Furnace Troubleshooting](#)
5. [How To Use A Straight Razor](#)

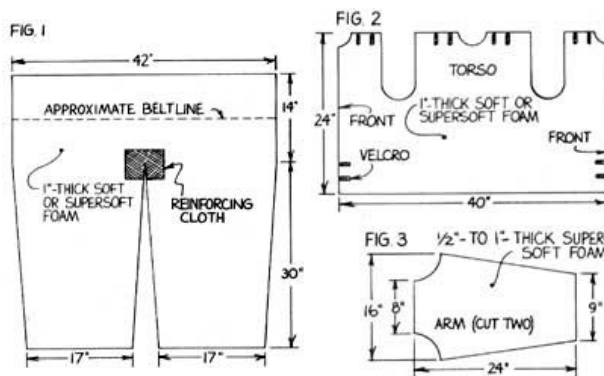

a 36" waist.) No matter what size legs you have, cut the foam legs 17" wide. A little creative customizing will probably be necessary to see that the foam fits both the pant and your leg.

You will also need to sew or glue a patch of reinforcing cloth—about 6 inches square—at the crotch to prevent tearing. (The top of the crotch should be in the center of the patch.) A glue specifically made for urethane foam can be purchased from the upholstery supply, or you

can use 3M Fast Tack Trim Adhesive, found in auto parts stores.

To put the parts together, simply roll up the foam legs and insert them inside the pant legs. With both foam legs in, you will have a pair of pants that will almost stand by themselves!

The shirt of this Eskimo-like outfit consists of the torso and the arms, all held in place by Velcro strips. (Velcro is usually sold by the foot at camping stores.) These can be glued on with the urethane glue at the abdomen and on each shoulder. The torso size shown in Fig. 2 should fit most adults, but as with the pants, you'll probably need to modify it some to fit your individual frame.

After you cut out the arms (see Fig. 3), roll them up and put them inside the sleeves of the shirt. Then wrap the foam torso around you and hook the Velcro strips that hold the torso piece in place. Now put the shirt on, and you're ready to go!

#### WARM ADVICE

For best results, the foam should be worn right next to your skin. Also, you may want to use suspenders to help keep the pants up.

If you have foam left over, make bun and knee pads. These are slipped in between the pants and the foam liner to give added warmth, in case you do any kneeling or sitting on the snow.

To keep your feet frostbite-free, Jim recommends using an old pair of Moon Boots or waders. Cut off the uppers, leaving only the soles, then sew on a cloth upper and wrap your feet in foam. Without socks you can be warm in weather as cold as 60° below—right down to your toes. Jim has used the same foam and a nylon shell to make mittens and even an arctic parka (which he made from an old Penny's jacket he bought at a garage sale for \$2.00).

So, as you can see, with these simple materials you can make everything you need in order to live comfortably at extremely cold temperatures. All that padding may make you look like an overstuffed Santa ... but you'll be a warm one!...

EDITOR'S NOTE: The folks here at MOTHER have not had a chance to try these clothes (at this writing, we're still waiting for our first frost!), so we recommend that you test them yourself on short outings before venturing out on a full winter expedition.

Jim Philips runs a school that teaches arctic living, winter camping, and cold-weather survival firsthand. For information about upcoming expeditions, write him at Without Fire or Shelter, 940 N. Sage Dr., Pleasant Grove, UT 84062.



Jim is ready to face any chilling weather in this outfit complete with mukluks, foam-filled mittens, and inexpensive foam-lined parka.



Jim's dad models his winter clothing before heading outdoors.



Cut foam pieces laid out and ready to be assembled.



All articles are reprinted just as they were published on the date indicated. Source listings, addresses and prices have not been updated; some details may have changed and terminology may be outmoded.

In some cases the scanning software used to create the digital articles has introduced typos into the text. In particular, the software often translated fractions incorrectly, i.e. "1/2" now reads as "112". We are working to correct these errors.

## Readers' Comments

### 1. dr jerry garber

am desperately trying to purchase a cloth patch from the faroe islands, to sew onto my photog vest. was not able to find when i was there 2 wks ago.

Wednesday, August 24, 2005 - 23:37:12

### 2. dr jerry garber

am desperately trying to purchase a faroe island cloth patch to sew onto my phography vest. was unable to fine same when there 2 wks ago

Wednesday, August 24, 2005 - 23:38:52

Name\*  E-Mail\*  Comment\*

\*Fields are required

Submit

## Subscribe now to Mother Earth News and save \$5.00



Yes, send me one year (6 issues) of Mother Earth News. Instead of paying the regular rate of \$19.95, I'll pay just \$14.95. That's a special price reflecting \$5.00 savings!

### Save More Money and Trees!

Pay with a credit card now and save an additional \$4.95. That's 6 issues of Mother Earth News for only \$10.00 (USA only).

Canadian subs: 1 year, \$22.95 (includes postage & GST). Foreign subs: 1 year, \$26.95. U.S. funds.

[Give a Gift Subscription](#)

First Name:

 \*

Last Name:

 \*

Address:

 \*

City:

 \*

State/Province:

Zip/Postal Code:

 \*

Country:

 \*

Email:

 \*

PAY NOW

BILL ME

(\* indicates a required item)

[Home](#) | [Subscribe](#) | [Customer Service](#) | [Advertising](#) | [Site Map](#) | [Contact Us](#) | [Privacy Policy](#) | [RSS Newsfeeds](#)

Copyright 2005, All Rights Reserved | Ogden Publications, Inc., 1503 SW 42nd St., Topeka, Kansas 66609-1265  
[Natural Home & Garden](#) • [Farm Collector](#) • [Gas Engine Magazine](#) • [Steam Traction](#) • [Herb Companion](#) • [Herbs for Health](#)  
[Grit Magazine](#) • [Cappers Magazine](#) • [Good Things to Eat](#) • [Brave Hearts](#)  
[Motorcycle Classics Magazine](#) • [Mother Earth News](#) • [Ogden Publications](#)